



Reservedele Spareparts Ersatzteile Pieces

**Maxidisc bugseret m. NSH
400/500/600
serie no. 679-xxx**

Indholdsfortegnelse,

Table of Contents, Inhaltsverzeichnis, Table des matières

RESERVEDELSLISTENS OPBYGNING, THE CONSTRUCTION OF THE SPAREPARTSLIST,	5
MAXIDISC 600, MAXIDISC, MAXIDISC, MAXIDISC	6
SIDESEKTION KPL. 600 VENSTRE, SEITENSEKTION LINKS, SIDE SEKTION LEFT, SECTION LATERALE GAUCHE	8
SIDESEKTION KPL. 600 HØJRE, SEITENSEKTION RECHTS, SIDE SEKTION RIGHT, SECTION LATERALE DROITE	10
HJULSTEL MAXIDISC KPL., RAD GESTELL, WHEEL FRAME, CADRE DE ROUE	12
NAV KPL. MONROC Ø60/A450, NABE, HUB, MOYEU	14
TRÆK KAT. 3 KOMPLET, ZUG, DRAWBAR, ATTELAGE	16
AFFJEDRINGSDEL HYDR., ABFEDERN, SPRINGING, SUSPENSION	18
NAV 5005NF M12-5/94/140 STARCO, NABE, HUB, MOYEU	20
TÆNDER KPL., CB-ZINKEN, CRACKERBOARD TINE, DENT CB	22
NAV T/SKIVE KPL. Ø35, NABE, HUB, MOYEU	24
EFTERLØBER 600 CM KPL., NÄCHLAUFER, ROLLER T-RING, TRAIINE ANNEAU-T	26
EFTERLØBER 600 CM U. T-RINGE, NÄCHLAUFER OHNE T-RINGE, ROLLER WITHOUT T-RING, TRAIINE PREPOSITION ANNEAU-T	28
SÆT RINGE PÅ AKSEL 300X60, SATZ RINGE FÜR DIE ACHSE, SHAFT RING SET, ANNEAUX SUR ARBRE	30
EFTERLØBER BOGIE 600 CM KPL., NÄCHLAUFER, ROLLER T-RING, TRAIINE ANNEAU-T	32
EFTERLØBER 600 CM U. T-RINGE, NÄCHLÄUFER OHNE T-RINGE, ROLLER WITHOUT T-RING, TRAIINE PREPOSITION ANNEAU-T	34
SÆT RINGE PÅ AKSEL 600X60, SATZ RINGE FÜR DIE ACHSE, SHAFT RING SET, ANNEAUX SUR ARBRE	36
HYDRAULIK	38
HYDRAULIK TIL HJULSTEL, RAD GESTELL HYDRAULIK, WHEEL FRAME HYDRAULIC, CADRE DE ROUE, HYDRAULIQUE	38
HYDRAULIK TIL DYBDEJUSTERING, HYDRAULIK TIEFENREGULIERUNG, HYDRAULIC DEPTH ADJUSTMENT, HYDRAULIQUE RÉGLAGE DE PROFOND	40
HYDRAULIK TIL OPKLAP TALL., HYDRAULIK AUS/ZUSAMMENKLAPPEN, HYDRAULIC FOLDING, HYDRAULIQUE DE REPLIAGE	42
HYDRAULIK TIL VINKELJUST. 600, HYD. WINKELREGULIERUNG, HYD. ANGLE ADJUSTMENT, AJUSTAGE D`ANGLE HYD.	44
HYDRAULIK TIL STENSIKRING MAXIDISC 400, HYDRAULIK, HYDRAULIC, HYDRAULIQUE	46
HYDRAULIK TIL STENSIKRING MAXIDISC 500, HYDRAULIK, HYDRAULIC, HYDRAULIQUE	48
HYDRAULIK TIL STENSIKRING MAXIDISC 600, HYDRAULIK, HYDRAULIC, HYDRAULIQUE	50
LYGTESÆT, LIGHT SET, LEUCHTSSATZ	52
LYGTESÆT MAXIDISC 500+600 KPL., LEUCHTSATZ, LIGHT SET, ENSEMBLE DE PHARES	52
BREMSER, BRAKES, BREMSE	54

TRYKLUFTBREMSE PÅ HJULSTEL, BREMSE AN RAD GESTELL, BREAKS ON WHEEL FRAME, FREIN DU CADRE DE ROUE	54
EKSTRAUDSTYR, OPTIONS, ZUSATZAUSRÜSTUNG, ACCESSOIRES EN OPTION	56
STÆNKLAP, RUPPER PLATE, SPRITZLAPPEN	56

Reservedelslistens opbygning, the construction of the sparepartslist,

<p>Reservedelstegningerne tager udgangspunkt i en Maxidisc 600. Ved de øvrige modeller er der udarbejdet en ekstra reservedelsliste hvor i forskellene fremgår</p>	<p>The spare parts drawings have there point of origin in a Maxidisc 600. For the other models there is made an extra spare parts list, where the differences is shown.</p>	<p>Die Ersatzteilzeichnungen sind ursprünglich von der Maxidisc 600. Für die anderen Typen gibt es eine separate Ersatzteilliste, die Unterschiede aufzeigt.</p>	<p>Les dessins des pièces détachées sont basés sur un Maxidisc 600. Pour les autres modèles une liste supplémentaire de pièces est établie où les différences sont montrées.</p>
<p>For deres sikkerhed samt for funktionsdygtigheden af deres maskine, bør der kun anvendes originale Dal-bo reservedele til deres maskine</p> <p>Når de bestiller reservedele bør de altid informere om:</p> <ul style="list-style-type: none"> • Reservedelsnummer • Maskinens typenummer • Antal styk af reservedelen 	<p>For your safety and for the functions of the machine, you should only use original spare parts form Dalbo.</p> <p>When you order spare parts, you should always inform about:</p> <ul style="list-style-type: none"> • Spare part number • The machine type number • Amount of spare parts pieces 	<p>Zu Ihrer Sicherheit und zur einwandfreien Funktion ihres Gerätes sollten sie unbedingt nur original DAL-BO Ersatzteile verwenden.</p> <p>Wenn sie Ersatzteile bestellen bitte folgendes beachten:</p> <ul style="list-style-type: none"> • Ersatzteil-Nummer • Geräte-Nummer und -typ • Anzahl der Ersatzteile 	<p>Pour votre sécurité et pour les fonctions du matériel, vous devez utiliser uniquement des pièces détachées d'origine DALBO.</p> <p>Lorsque vous commandez vos pièces détachées, vous devez toujours nous indiquer :</p> <ul style="list-style-type: none"> • Le numéro de la pièce • Le type de la machine • La quantité des pièces détachées.

Maxidisc 600, maxidisc, maxidisc, maxidisc

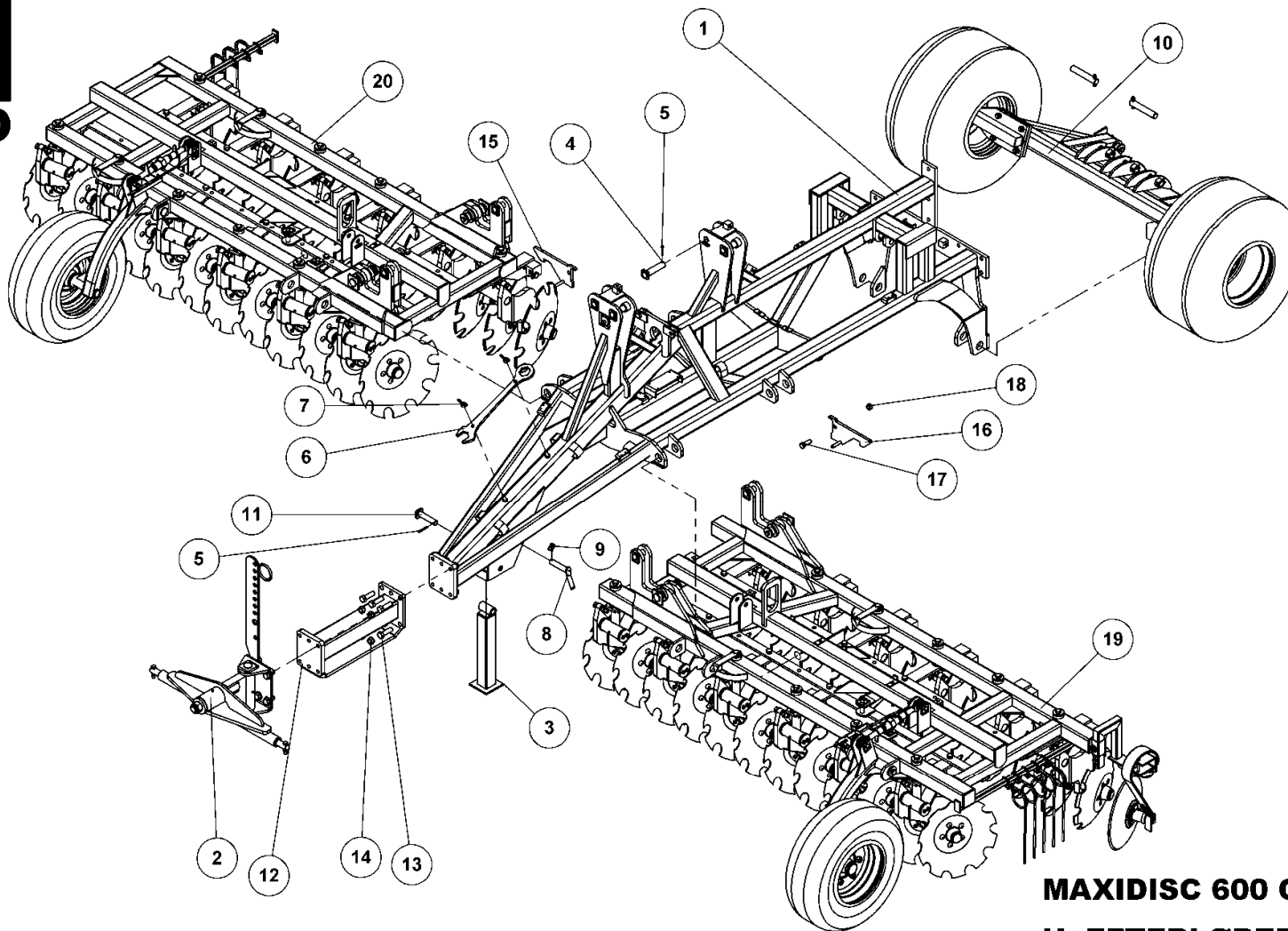

**MAXIDISC 600 CM HYDR. AFFJ.
U. EFTERLØBER**

MAXIDISC
MAXIDISC
MAXIDISC

80025

side 6



MAXIDISC 600 CM HYDR. AFFJ.

U. EFTERLØBER

80025

MAXIDISC
MAXIDISC
MAXIDISC

Pos.	Qty.	Part nr.	Benævnelse	Bezeichnung	Description	Designation
1	1	80451	HØVEDRAMME TIL MAXIDISC	HAUPTTRAHMEN	MAIN FRAME	CHASSIS
2	1	74270	TRÆK KAT. 3. KOMPLET	ZUG	DRAWBAR	ATTELAGE
3	1	74222	STØTTEBEN	STUTZFUSS	JACK	BÉQUILLE
4	4	80469	NAGLE F Ø35X130(158)	BOLZEN	PIN	AXE
5	5	90677	SPLIT 8X50 MM GALV.	SPLINT	SPLIT PIN	GOUPILLE
6	1	57550	GAFFELNØGLE 60 MM	SCHLÜSSEL	SPANNER	CLE DE FOURCHETTE
7	2	92095	MØTRIK M16_VINGE	MUTTER	WING NUT	ÉCROU
8	1	74313	NAGLE H Ø30X120(135)	BOLZEN	PIN	AXE
9	1	90680	RINGSPLIT Ø 8X40 FLAD	RINGSPLINT	LINCH PIN	GOUPILLE
10	1	80080	HJULSTEL MAXIDISC KPL	RAD GESTELL	WHEEL FRAME	CADRE DE ROUE
11	1	25452	NAGLE F Ø30X120(148)	AXE	PIN	BOLZEN
12	1	74277	FORLÆNGERSTYKKE TIL AXR-H TRÆK	VERLÄNGERUNGSSTÜCK FÜR DEN AXR-H ZUG	EXTENSION PIECE FOR AXR-H LINKAGE	RALLONGE POUR ATTELAGE
13	6	92351	BOLT 24x80 8.8 GALV.	SCHRAUBE	SCREW	BOLON
14	11	92053	MØTRIK M24 SELVLÅS. GLV.8	MUTTER	SELF-LOCKING NUT	ÉCROU
15	1	80075	TRANSPORTLÅS HØJRE, MAXIDISC	TRANSPORTSICHERUNG KPL. RECHTS	TRANSPORT LOCK	SYSTÈME DE VÉROUILLAGE DE TRANSPORT DROITE
16	1	80076	TRANSPORTLÅS VENSTRE, MAXIDISC	TRANSPORTSICHERUNG KPL. LINKS	TRANSPORT LOCK	SYSTÈME DE VÉROUILLAGE DE TRANSPORT GAUCHE
17	2	92334	BOLT 20x60 8.8 GALV.	SCHRAUBE	SCREW	BOLON
18	2	92052	MØTRIK M 20 SELVLÅS. GALV. 8	MUTTER SELBSTGESICHERT	SELF-LOCKING NUT	ÉCROU DE SÉCURITÉ
19	1	80208	SIDESEKTION KPL. 600 VENSTRE	SEITENSEKTION LINKS	SIDE SEKTION LEFT	SECTION LATÉRALE GAUCHE
20	1	80209	SIDESEKTION KPL. 600 HØJRE	SEITENSEKTION RECHTS	SIDE SEKTION RIGHT	SECTION LATÉRALE DROITE

MAXIDISC 400/500 CM U.EFTERLØBER

80007/80015

Maxidisc
Maxidisc
Maxidisc

Pos.	Qty.	Part nr.	Benævnelse	Bezeichnung	Description	Designation
19	1	80236	Sidesektion kpl. 500 venstre	Seitensektion links	Side sektion left	Section laterale gauche
20	1	80237	Sidesektion kpl. 500 højre	Seitensektion rechts	Sidesektion right	Section laterale droite
19	1	80238	Sidesektion kpl. 400 venstre	Seitensektion links	Sidesektion left	Section laterale gauche
20	1	80239	Sidesektion kpl. 400 højre	Seitensektion rechts	Sidesektion right	Section laterale droite

Sidesektion kpl. 600 venstre, seitensektion links, side sektion left, section laterale gauche

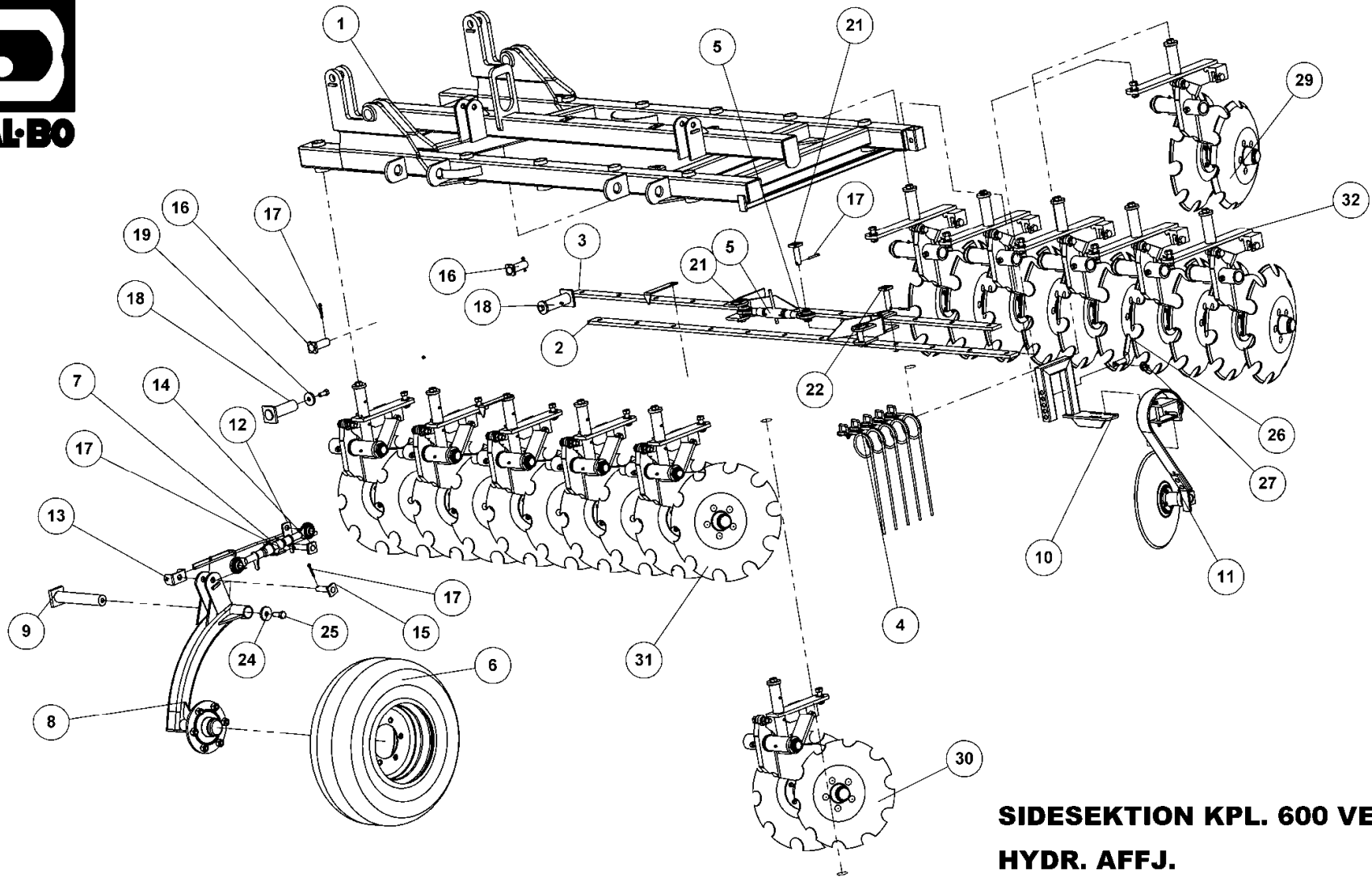

**SIDeseKTIon KPl. 600 VenSTRE
HyDR. AffJ.**

SEITENSEKTIon LINKS
SIDE SEKTIon LEFT
SECTIon LATeRALE GAUCHE.

80208



SIDESEKTION KPL. 600 VENSTRE

HYDR. AFFJ.

80208

SEITENSEKTION LINKS
SIDE SEKTION LEFT
SECTION LATÉRALE GAUCHE.

Pos.	Qty.	Part nr.	Benævnelse	Bezeichnung	Description	Designation
1	1	80481	SIDERAMME 600 VENSTRE HYDR. AFFJ.	SEITENRAHMEN LINKS	SIDE FRAME, LEFT	CADRE LATÉRAL GAUCHE
2	1	80460	AFSTANDSBOM 12 HULS M/FÆSTE	DISTANZSSTÜCK	SPACER	BAGUE DE DISTANCE
3	1	80502	AFSTANDSBOM 12 HULS M/FÆSTE	DISTANZSSTÜCK	SPACER	BAGUE DE DISTANCE
4	5	14804	HARVETAND 10X100 KPL	ZINKEN	SPRING TINE	DENT DE HERSE
5	1	51310	TOPSTANG 1"X1"X350-500	OBERLENKER	TOP LINK	BARRE
6	1	12318	HJUL 10.0/75-15.3 - 10 PLY AW	RAD	WHEEL	ROUE
7	1	90851	TOPSTANG SVÆR 1"X1"X350-500 KAT. 2	OBERLENKER	TOP LINK	BARRE
8	1	80586	STØTTEHJULSARM KPL. VENSTRE	STÜTZE	SUPPORT	FIXATION
9	1	74304	NAGLE F Ø50X298	BOLZEN	PIN	AXE
10	1	80524	HOLDER FOR VOLDJÆVNER KPL.	HALTER DER EGGENSEKTION	MOUNT FOR HARROW SECTION	SUPPORT DE SECTION-HERSE
11	1	91896	LAMELTAND 80MM BRED KPL.	CB-ZINKEN	CRACKERBOARD TINE	DENT CB
12	1	80472	DYBDEMÅRKNING TIL STØTTEHJUL ØVERST	TIEFENMESSER	DEPTH INDICATOR	INDICATEUR DE PROFONDEUR
13	1	80719	DYBDEMÅLER TIL STØTTEHJUL NEDERST	TIEFENMESSER	DEPTH INDICATOR	INDICATEUR DE PROFONDEUR
14	1	72276	NAGLE F Ø25X95(123)	BOLZEN	PIN	AXE
15	1	79249	NAGLE F Ø25X80(107)	BOLZEN	PIN	AXE
16	2	74308	NAGLE F Ø35X80(108)	BOLZEN	PIN	AXE
17	8	90677	SPLIT ØX50 MM GALV.	SPLINT	SPLIT PIN	GOUPILLE
18	2	80477	NAGLE F Ø50X155(170)M16	BOLZEN	PIN	AXE
19	2	71570	SKIVE Ø17,5-Ø61-10	SCHIBE	WASHER	RONDELLE
20	2	92316	BOLT 16x40 8.8 GALV. (SÆTBOLT)	SCHRAUBE	SET SCREW	BOULON
21	3	74312	NAGLE F Ø25X75(103)	BOLZEN	PIN	AXE
22	1	72275	NAGLE F Ø25X85(113)	BOLZEN	PIN	AXE
23	2	80638	VINKELMARKERING	INDIKATOR	INDICATOR	INDICATEUR
24	1	74529	SKIVE Ø21-Ø69-10	UNTERLEGSCHEIBE	WASHER	RONDELLE DE SERRAGE
25	1	92335	BOLT 20x50 8.8 GALV. (SÆTBOLT)	SCHRAUBE	SET SCREW	BOULON
26	1	22289	NAGLE H Ø20X60(75)	BOLZEN	PIN	AXE
27	1	90680	RINGSPLIT Ø 8X40 FLAD	RINGSPLINT	LINCH PIN	GOUPILLE
28	3	90721	SMØRENIPPEL M8x1	SCHMIERNIPPEL	GREASE NIPPLE	GRAISSEUR
29	1	80453	AFFJEDRINGSDEL BAG - VENSTRE YDERST	ABFEDERN	SPRINGING	SUSPENSION
30	1	80489	AFFJEDRINGSDEL FOR - YDERST VENSTRE	ABFEDERN	SPRINGING	SUSPENSION
31	5	80456	AFFJEDRINGSDEL FOR	ABFEDERN	SPRINGING	SUSPENSION
32	5	80455	AFFJEDRINGSDEL BAG	ABFEDERN	SPRINGING	SUSPENSION

Sidesektion 400/500 venstre

80238/80236

Pos.	Qty.	Part nr.	Benævnelse	Bezeichnung	Description	Designation
1	1	80476	Sideramme 500 venstre	Seitenrahmen links	Side frame, left	Cadre latéral gauche
2	1	80483	Afstandsbom, for 500	Distanzsstück	Spacer	Bague de distance
3	1	80484	Afstandsbom, bag 500	Distanzsstück	Spacer	Bague de distance
32	4	80456	Affjedring for	Abfedern	Springing	Suspension
33	4	80455	Affjedring bag	Abfedern	Springing	Suspension
1	1	80474	Sideramme 400 venstre	Seitenrahmen links	Side frame, left	Cadre latéral gauche
2	1	80360	Afstandsbom, for 400	Distanzsstück	Spacer	Bague de distance
3	1	80362	Afstandsbom, bag 400	Distanzsstück	Spacer	Bague de distance
32	3	80456	Affjedring for	Abfedern	Springing	Suspension
33	3	80455	Affjedring bag	Abfedern	Springing	Suspension

Sidesektion kpl. 600 højre, seitensektion rechts, side sektion right, section laterale droite

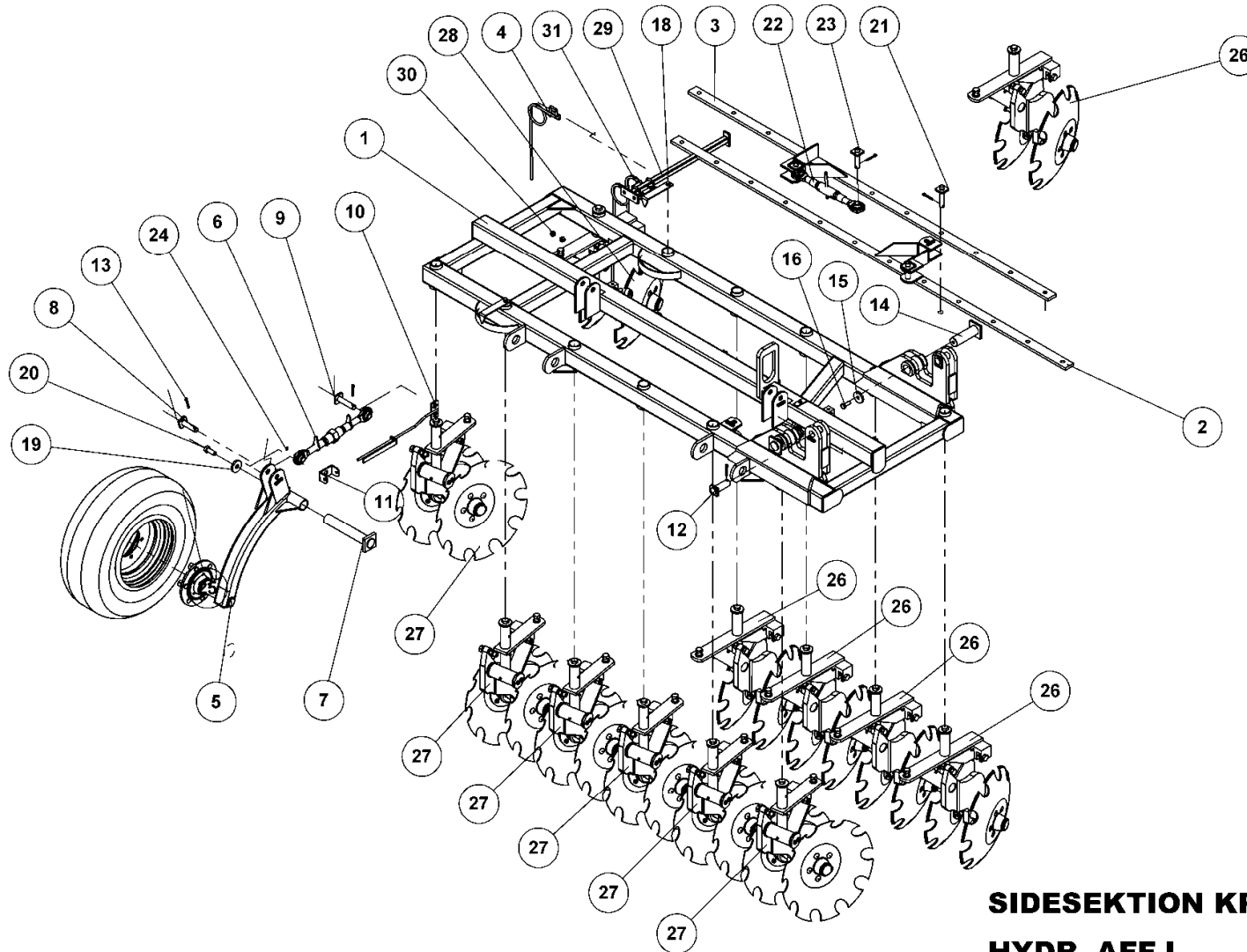

**SIDESEKTION KPL. 600 HØJRE
HYDR. AFFJ.**

SEITENSEKTION RECHTS
SIDE SEKTION RIGHT
SECTION LATERALE DROITE

80209



SIDESEKTION KPL. 600 HØJRE

HYDR. AFFJ.

80209

SEITENSEKTION RECHTS
SIDE SEKTION RIGHT
SECTION LATÉRALE DROITE

Pos.	Qty.	Part nr.	Benævnelse	Bezeichnung	Description	Designation
1	1	80480	SIDERAMME 600 HØJRE HYDR. AFFJ.	SEITENRAHMEN RECHTS	SIDE FRAME, RIGHT	CADRE LATÉRAL DROITE
2	1	80501	AFSTANDSBOM 12 HULS M/FÆSTE	DISTANZSSTÜCK	SPACER	BAGUE DE DISTANCE
3	1	80408	AFSTANDSBOM- 11 HULS M. FÆSTE	DISTANZSSTÜCK	SPACER	BAGUE DE DISTANCE
4	3	14804	HARVETAND 10X100 KPL	ZINKEN	SPRING TINE	DENT DE HERSE
5	1	80587	STØTTEHJULSARM KPL. HØJRE	STÜTZE	SUPPORT	FIXATION
6	1	90851	TOPSTANG SVÆR 1"X1"X350-500 KAT. 2	OBERLENKER	TOP LINK	BARRE
7	1	74304	NAGLE F Ø50X298	BOLZEN	PIN	AXE
8	1	79249	NAGLE F Ø25X80(107)	BOLZEN	PIN	AXE
9	1	72276	NAGLE F Ø25X95(123)	BOLZEN	PIN	AXE
10	1	80472	DYBDEMARKERING TIL STØTTEHJUL ØVERST	TIEFENMESSER	DEPTH INDICATOR	INDICATEUR DE PROFONDEUR
11	1	80719	DYBDEMÅLER TIL STØTTEHJUL NEDERST	TIEFENMESSER	DEPTH INDICATOR	INDICATEUR DE PROFONDEUR
12	2	74308	NAGLE F Ø35X80(108)	BOLZEN	PIN	AXE
13	8	90677	SPLIT 8X50 MM GALV	SPLINT	SPLIT PIN	GOUPILLE
14	2	80477	NAGLE F Ø50X155(170)M16	BOLZEN	PIN	AXE
15	2	71570	SKIVE Ø17,5-Ø61-10	SCHIBE	WASHER	RONDELLE
16	2	92316	BOLT 16x40 8.8 GALV. (SÆTBOLT)	SCHRAUBE	SET SCREW	BOULON
17	1	80458	LÅS KPL. HØJRE FORAVENSTRE BAG	RIEGLE	LOCK	COUVRE
18	2	80638	VINKELMARKERING	INDIKATOR	INDICATOR	INDICATEUR
19	1	74529	SKIVE Ø21-Ø69-10	UNTERLEGSCHIBE	WASHER	RONDELLE DE SERRAGE
20	1	92335	BOLT 20x50 8.8 GALV. (SÆTBOLT)	SCHRAUBE	SET SCREW	BOULON
21	1	72275	NAGLE F Ø25X85(113)	BOLZEN	PIN	AXE
22	1	51310	TOPSTANG 1"X1"X350-500	OBERLENKER	TOP LINK	BARRE
23	3	74312	NAGLE F Ø25X75(103)	BOLZEN	PIN	AXE
24	3	90721	SMØRENIPPEL M8x1	SCHMIERNIPPEL	GREASE NIPPLE	GRAISSEUR
25	1	12318	HJUL 10.0/75-15.3 - 10 PLY AW	RAD	WHEEL	ROUE
26	5	80455	AFFJEDRINGSDEL BAG	ABFEDERN	SPRINGING	SUSPENSION
27	6	80456	AFFJEDRINGSDEL FOR	ABFEDERN	SPRINGING	SUSPENSION
28	1	80452	AFFJEDRINGSDEL BAG - HØJRE YDERST	ABFEDERN	SPRINGING	SUSPENSION
29	1	80635	ARM TIL STRIGLET/ENDER	ARM	ARM	BRAS
30	2	92051	MØTRIK M16 SELVLÅS. GLV.8	MUTTER	SELF-LOCKING NUT	ÉCROU
31	2	92317	BOLT 16x50 8.8 GALV. (SÆTBOLT)	SCHRAUBE	SET SCREW	BOULON

Sidesektion kpl. 400/500 højre

80239/80237

Pos.	Qty.	Part nr.	Benævnelse	Bezeichnung	Description	Designation
1	1	80475	Sideramme 500 højre	Seitenrahmen rechts	Side frame, right	Cadre latéral droite
2	1	80482	Afstandsbom 10 huls m. fæste	Distanzsstück	Spacer	Bague de distance
3	1	80485	Afstandsbom 9 huls m. fæste	Distanzsstück	Spacer	Bague de distance
26	4	80455	Affjedring bag	Abfedern	Springing	Suspension
27	5	80456	Affjedring for	Abfedern	Springing	Suspension
1	1	80473	Sideramme 400 højre	Seitenrahmen rechts	Side frame, right	Cadre latéral droite
2	1	80363	Afstandsbom, for 400	Distanzsstück	Spacer	Bague de distance
3	1	80361	Afstandsbom, bag 400	Distanzsstück	Spacer	Bague de distance
26	3	80455	Affjedring bag	Abfedern	Springing	Suspension
27	4	80456	Affjedring for	Abfedern	Springing	Suspension

Hjulstel maxidisc kpl., rad gestell, wheel frame, cadre de roue

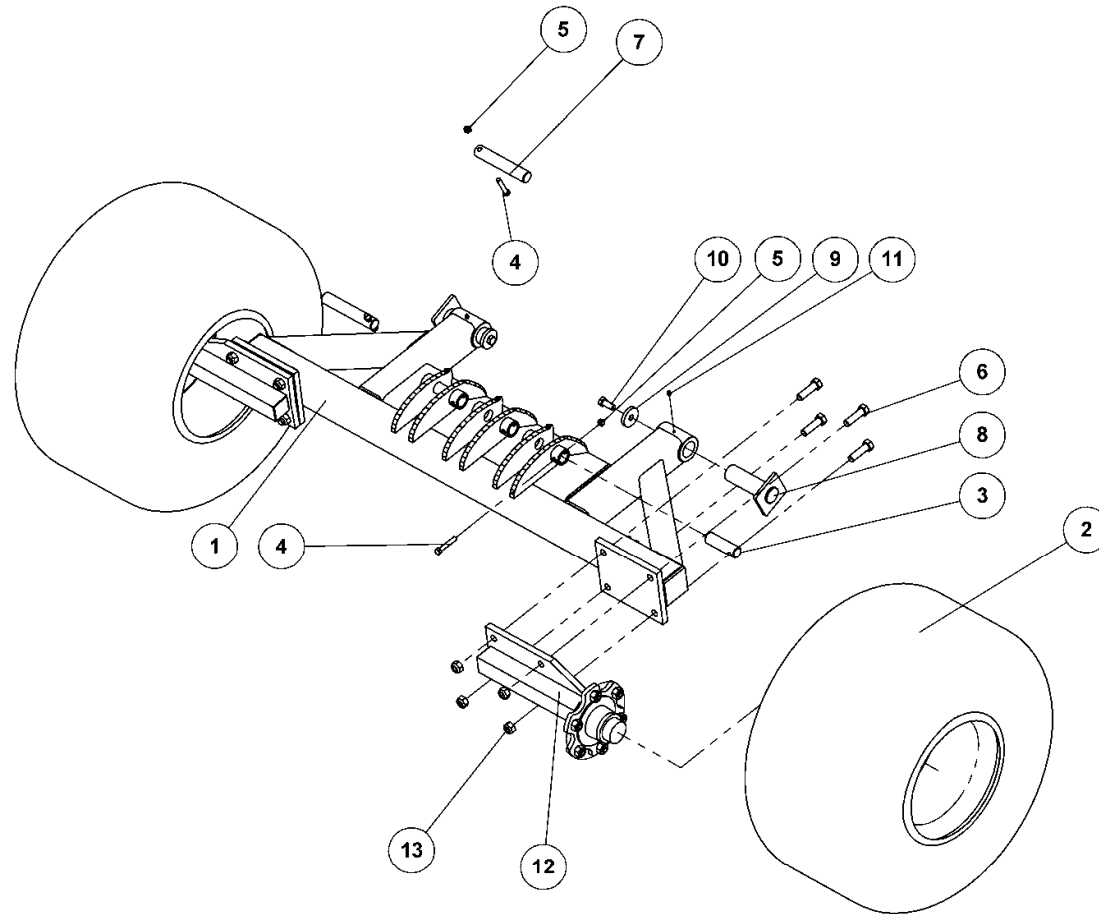

HJULSTEL MAXIDISC KPL.

RAD GESTELL
WHEEL FRAME
CADRE DE ROUE

80080



HJULSTEL MAXIDISC KPL.

80080

RAD GESTELL
WHEEL FRAME
CADRE DE ROUE

Pos.	Qty.	Part nr.	Benævneelse	Bezeichnung	Description	Designation
1	1	80489	HJULSTEL, EN/TO CYLINDRE	RAD GESTELL	WHEEL FRAME	CADRE DE ROUE
2	2	25261	HJUL KPL. 520/50-17 - 14 PLY	RAD	WHEEL	ROUE
3	2	71559	NAGLE U Ø35X85(115)	AXE	PIN	BOLZEN
4	4	92299	BOLT 12x70 8.8 GALV.	SCHRAUBE	SCREW	BOULON
5	4	92050	MØTRIK M12 SELVLÅS. GLV. 8	MUTTER SELBSTSCHLIESSEND	SELFLOCKING NUT	ÉCROU DE SÉCURITÉ
6	8	92342	BOLT 20x70 8.8 GALV.	SCHRAUBE	SCREW	BOULON
7	2	71560	NAGLE U Ø35X175(200)	AXE	PIN	BOLZEN
8	2	74316	NAGLE F Ø50X155(170)M16	BOLZEN	PIN	AXE
9	2	71570	SKIVE Ø17,5-Ø61-10	SCHIBE	WASHER	RONDELLE
10	2	92316	BOLT 16x40 8.8 GALV. (SÆTBOLT)	SCHRAUBE	SET SCREW	BOULON
11	2	90721	SMØRENIPPEL M8x1	SCHMIERNIPPEL	GREASE NIPPLE	GRAISSEUR
12	2	25220	NAV MED FLANGE	NABE	HUB	MOYEU
13	8	92052	MØTRIK M 20 SELVLÅS. GALV. 8	MUTTER SELBSTGESICHERT	SELF-LOCKING NUT	ÉCROU DE SÉCURITÉ

Nav kpl. MONROC Ø60/A450, nabe, hub, moyeu

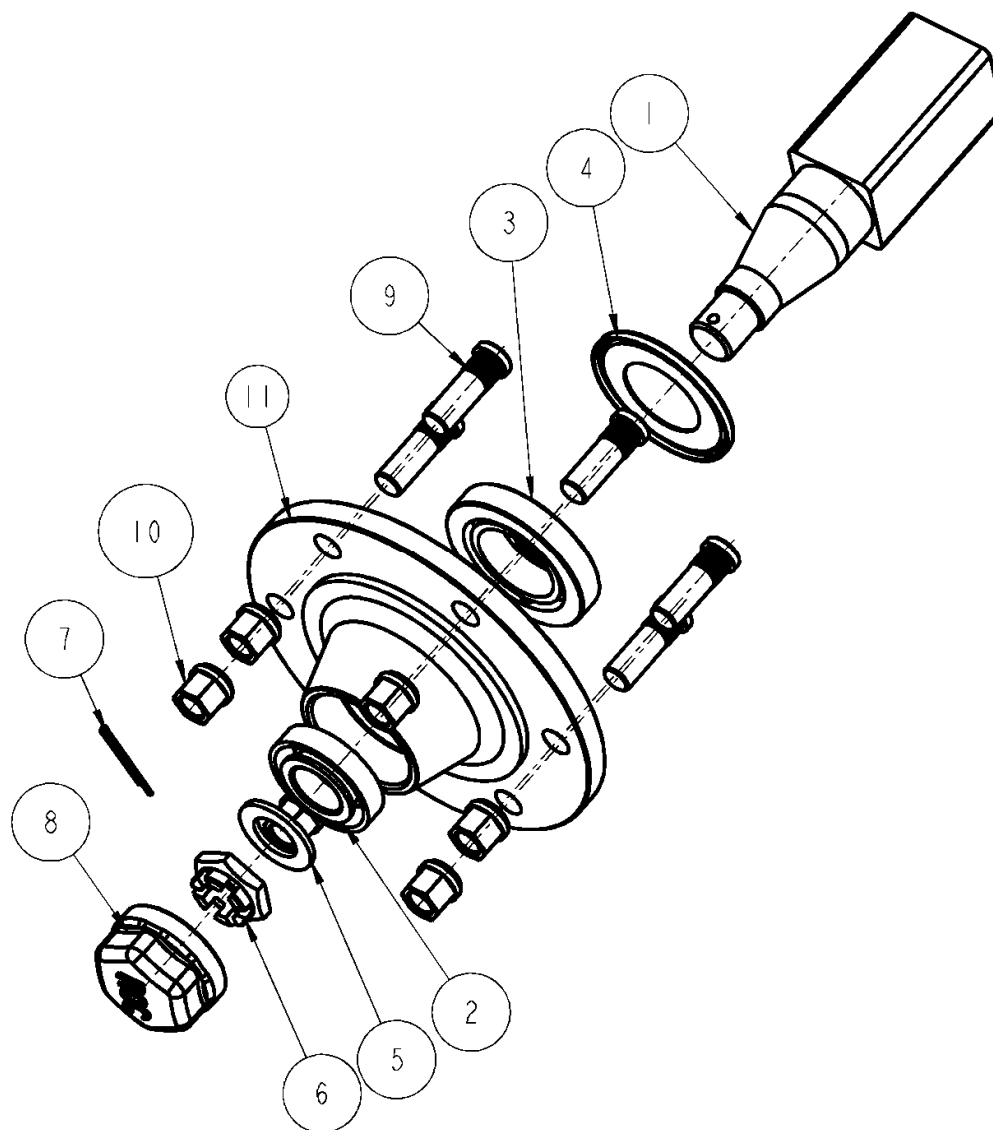

33207

side 14

NAV KPL. MONROC Ø60/A450, NABE, HUB, MOYEU

33207

Pos.	Qty.	Part nr.	Benævnelse	Bezeichnung	Description	Designation
1	1	33210	AKSEL	WELLE	SHAFT	ARBRE
2	1	12849	LEJE 30207	LAGER	BEARING	FIXATION
3	1	12863	LEJE 30211	LAGER	BEARING	FIXATION
4	1	33211	TÆTNINGSRING	DICHTUNGSRING	SEAL	BAGUE D'ÉTANCHEITE
5	1	33212	SKIVE 31X52X4	SCHEIBE	WASHER	RONDELLE DE SERRAGE
6	1	33213	KRONEMØTRIK	ACHSENMUTTER	SHAFT NUT	ECROU D'ARBRE
7	1	33214	SPLIT	SPLINTE	SPLIT PIN	GOUPILLE
8	1	33215	NAVKAPSEL	NABEKAPSEL	HUB CAP	BOITE DE MOYEU
9	6	23452	NAVBOLT M18X1,5 - 40/54	SCHRAUBE	SCREW	BOULON
10	6	23453	NAVMØTRIK M18	MUTTER	NUT	ECROU

Træk kat. 3 komplet, zug, drawbar, attelage

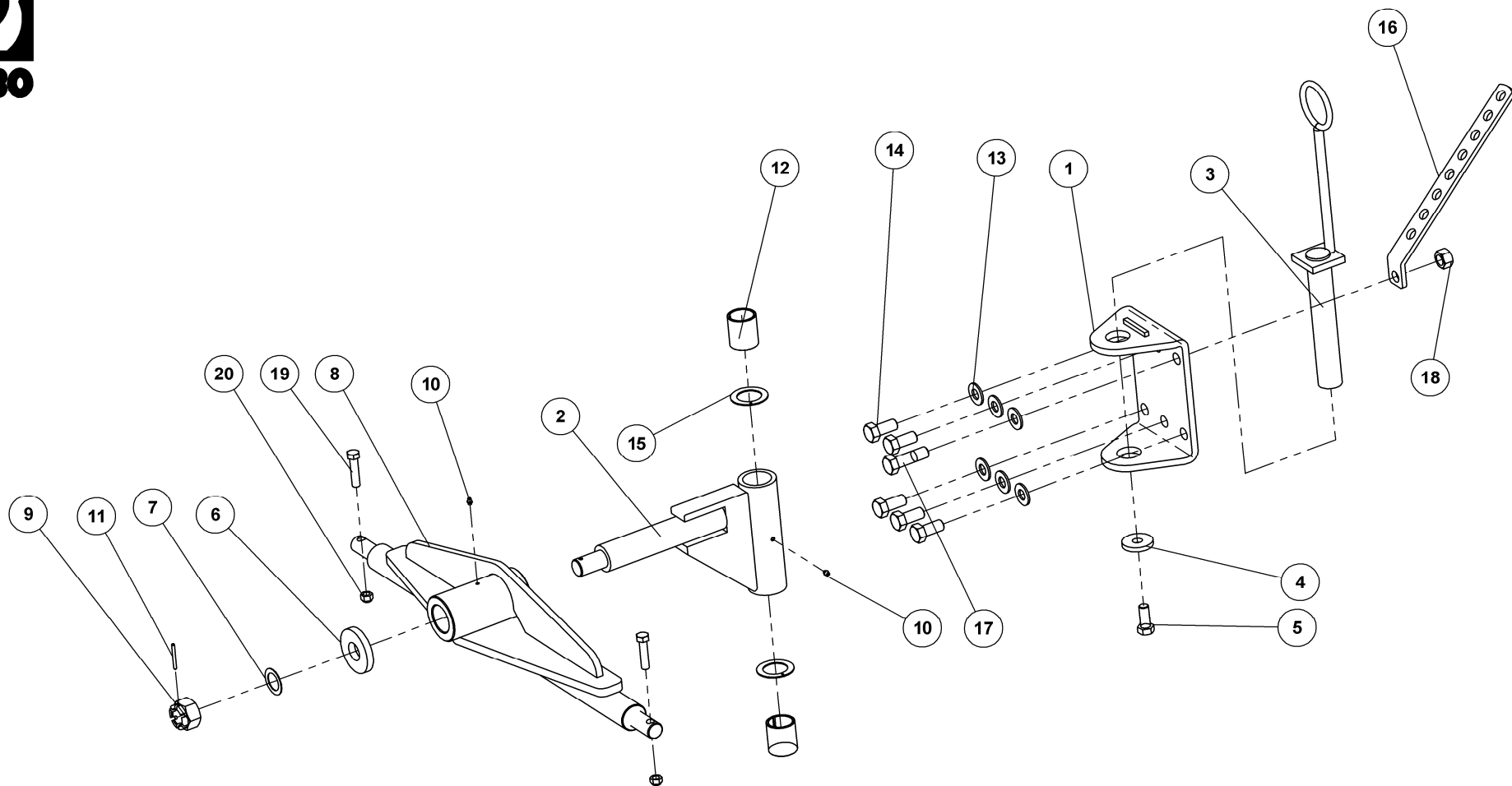

TRÆK KAT. 3, KOMPLET

ZUG
DRAWBAR
ATTELAGE

74270

side 16



TRÆK KAT. 3, KOMPLET

74270

ZUG
DRAWBAR
ATTELAGE

Pos.	Qty.	Part nr.	Benævnelse	Bezeichnung	Description	Designation
1	1	74273	FLANGE TIL TRÆK KPL.	ZUGFLANSCH GEBEUGT	FLANGE	ALIE D'ATTELAGE COUBÉE
2	1	74272	TRÆK NAV	ZUG	DRAWBAR HUB	ATTELAGE
3	1	74300	NAGLE F Ø50X298(318)M20	BOLZEN	PIN	AXE
4	1	74529	SKIVE Ø22,5-Ø65-10	UNTERLEGSCHIEBE	WASHER	RONDELLE DE SERRAGE
5	1	92335	BOLT 20x50 8.8 GALV. (SÆTBOLT)	SCHRAUBE	SET SCREW	BOULON
6	1	71380	SKIVE Ø41-Ø100-15	SCHEIBE	WASHER	RONDELLE
7	1	90635	SKIVE Ø40-Ø60-1,5	SCHEIBE ROSTFREI	WASHER	RONDELLE INROUILLABLE
8	1	74274	TRÆK KAT. 3 AXR-H	ZUG	DRAWBAR	ATTELAGE
9	1	72384	AKSELNØTRIK M39x3, NV 60 GLV. KI.8	ACHSENMUTTER	SHAFT NUT	ÉCROU D'ARBRE
10	2	90721	SMØRENIPPEL M8x1	SCHMIERNIPPEL	GREASE NIPPLE	GRAISSEUR
11	1	90688	RØRSTIFT Ø 6X60 MM	ROHRSTIFT	SPLIT PIN	AXE TUBULAIRE
12	2	59300	BRONCEBØSNING Ø60/Ø50 X 70	DOUILLE EN BRONZE	BRONZE BUSHING	BRONZEBUCHSE
13	6	90665	SKIVE Ø24-Ø49-4	UNTERLEGSCHIEBE	WASHER	RONDELLE DE SERRAGE
14	5	92427	BOLT 24x50 GALV 8.8 (SÆTBOLT)	SCHRAUBE	SET SCREW	BOULON
15	2	71251	FORSMURT TRYKSKIVE - Ø78/Ø52/2,6MM	VORGESCHMIERTE DRUCKSCHEIBE	GREASED THRUST WASHER	RONDELLE DE PRESSION LUBRIFIÉE D'USINE
16	1	80793	SLANGEHOLDER MAXIDISC	SCHLAUCHHALTER	HOSE CLAMP	SUPPORT DE TUYAU
17	1	92350	BOLT 24x80 8.8 GALV. (SÆTBOLT)	SCHRAUBE	SET SCREW	BOULON
18	1	92033	MØTRIK M24 GALV. KI.8	MUTTER	NUT	ÉCROU
19	2	92319	BOLT 16x70 8.8 GALV.	SCHRAUBE	SCREW	BOULON
20	2	92051	MØTRIK M16 SELVLÅS. GLV.8	MUTTER	SELF-LOCKING NUT	ÉCROU

Affjerdingsdel hydr., abfedern, springing, suspension

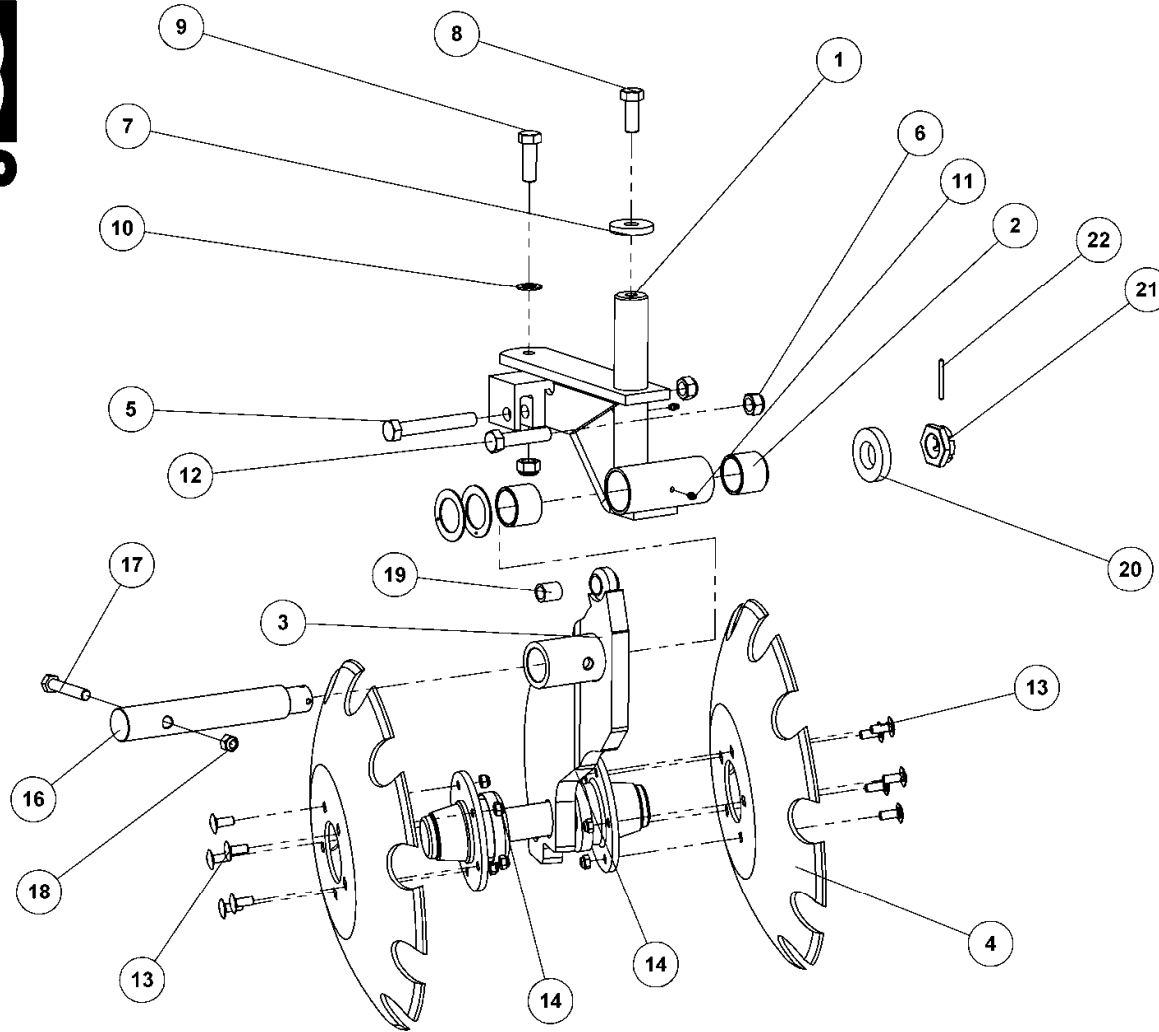

**AFFJEDRINGSDEL FOR
HYDR. AFFJ.**

ABFEDERN
SPRINGING
SUSPENSION

80456



AFFJEDRINGSDEL FOR

HYDR. AFFJ.

80456

ABFEDERN
SPRINGING
SUSPENSION

Pos.	Qty.	Part nr.	Benævnelse	Bezeichnung	Description	Designation
1	1	80962	NAVSENSFÆSTE FOR - FREMRYKKET	BEFESTIGUNG FÜR NABEBEIN	MOUNTING FOR HUB LEG	FIXATION POUR PIED DE MOYEU
2	2	91912	BRONCEBØSNING 50-60-45	BRONZEBUCHSE	BRONZE BUSHING	DOUILLE EN BRONZE
3	1	80953	NAV BEN FORREST 250805	NABEBEIN	HUB LEG	PIED DE MOYEU
4	2	80388	TALLERKEN Ø560 (SPECIEL)	SCHIBE GEZAHNT	DISC, NOTCHED	DISQUE DENTÉ
5	1	92340	BOLT 20x140 8.8 GALV.	SCHRAUBE	SCREW	BOULON
6	3	92052	MØTRIK M 20 SELVLÅS, GALV. 8	MUTTER SELBSTGESICHERT	SELF-LOCKING NUT	ÉCROU DE SÉCURITÉ
7	1	74529	SKIVE Ø21-Ø69-10	UNTERLEGSCHIBE	WASHER	RONDELLE DE SERRAGE
8	1	92335	BOLT 20x50 8.8 GALV. (SÆTBOLT)	SCHRAUBE	SET SCREW	BOULON
9	1	92334	BOLT 20x60 8.8 GALV.	SCHRAUBE	SCREW	BOULON
10	1	90671	SKIVE Ø21-Ø37-3	UNTERLEGSCHIBE	WASHER	RONDELLE DE SERRAGE
11	2	90721	SMØRENIPPEL M8x1	SCHMIERNIPPEL	GREASE NIPPLE	GRAISSEUR
12	1	92372	BOLT 20x90 8.8 GALV.	SCHRAUBE	SCREW	BOULON
13	10	92392	BOLT 12X30 GALV. (BRÆDDEBOLT)	SCHRAUBE	BOARD BOLT	BOULON
14	10	92050	MØTRIK M12 SELVLÅS, GLV. 8	MUTTER SELBSTSCHLIESSEND	SELFLOCKING NUT	ÉCROU DE SÉCURITÉ
15	2	71251	FORSMURT TRYKSKIVE - Ø78/Ø52/2.6MM	VORGESCHMIERTE DRUCKSCHIBE	GREASED THRUST WASHER	RONDELLE DE PRESSION LUBRIFIÉE D'USINE
16	1	80947	NAGLE Ø50 FOR NSH AFFJ. MAXIDISC			
17	1	92321	BOLT 16x90 8.8 GALV.	SCHRAUBE	SCREW	BOULON
18	1	92051	MØTRIK M16 SELVLÅS, GLV. 8	MUTTER	SELF-LOCKING NUT	ÉCROU
19	1	91908	BRONCEBØSNING Ø28/Ø20-30	BRONZEBUCHSE	BRONZE BUSHING	DOUILLE EN BRONZE
20	1	72264	TOPSKIVE TIL CENTERNAGLE	SCHIBE FÜR ZENTRALNAGEL	TOP WASHER FOR CENTER PIN	RONDELLE DE SOMMET POUR MOYEU CENTRAL
21	1	92518	KRONEMØTRIK M39X3	ACHSENMUTTER	SHAFT NUT	ÉCROU D'ARBRE
22	1	90688	RØRSTIFT Ø 6X60 MM	ROHRSTIFT	SPLIT PIN	AXE TUBULAIRE

Affjedringsdel hydr.

Abfedern
Springing
Suspension

80455

Pos.	Qty.	Part nr.	Benævnelse	Bezeichnung	Description	Designation
1	1	80963	NAVSENSFÆSTE BAG - FREMRYKKET	BEFESTIGUNG FÜR NABEBEIN	MOUNTING FOR HUB LEG	FIXATION POUR PIED DE MOYEU
3	1	80954	NAV BEN BAGERST 250805	NABEBEIN	HUB LEG	PIED DE MOYEU

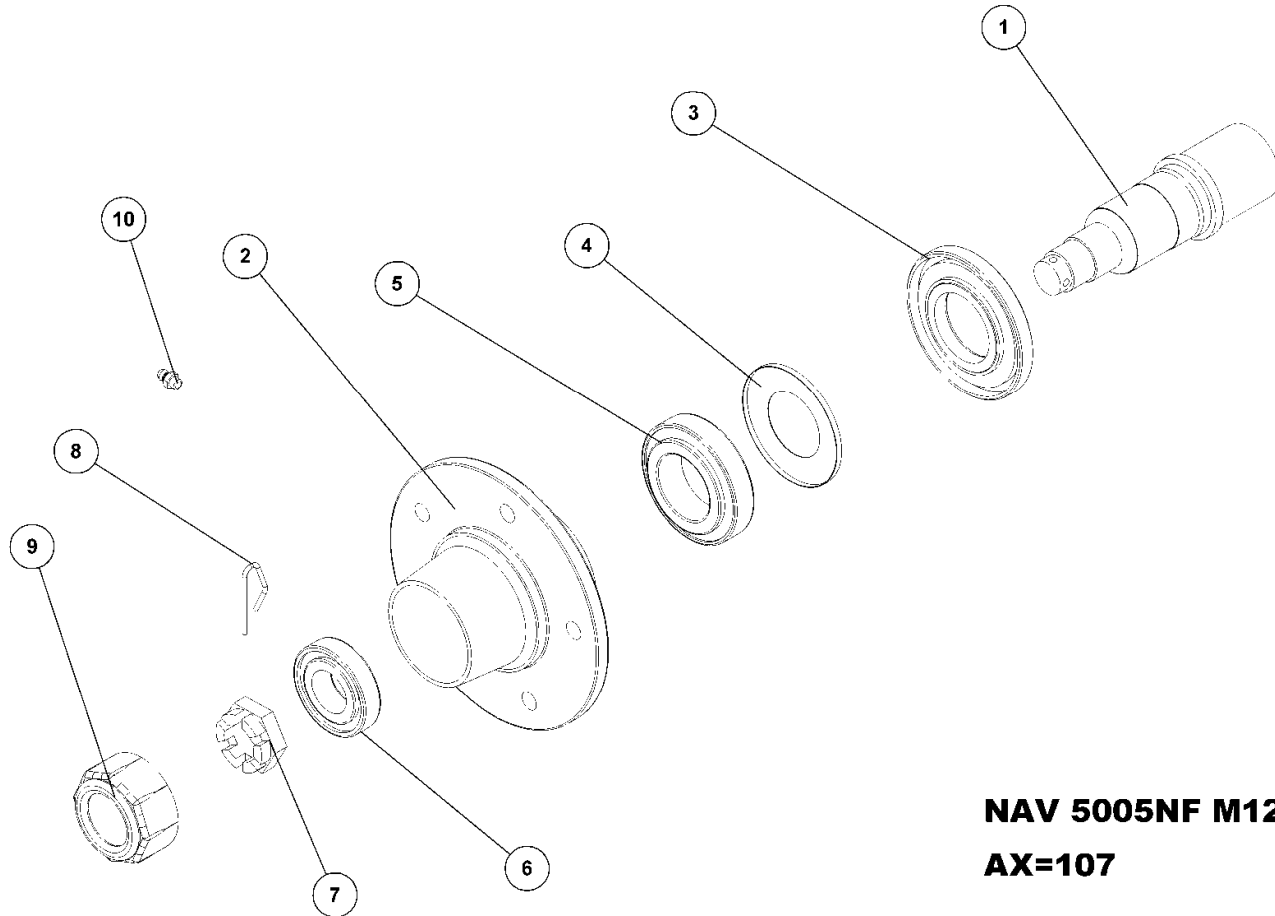

NAV 5005NF M12-5/94/140 STARCO
AX=107

NABE
HUB
MOYEU

80824

**NAV 5005NF M12-5/94/140 STARCO AX=107****80824**NABE
HUB
MOYEU

Pos.	Qty.	Part nr.	Benævnelse	Bezeichnung	Description	Designation
1	1	80982	AKSEL Ø50 FOR STARCO NAV 80824	WELLE	SHAFT	ARBRE
2	1	80983	NAVHUS FOR STARCO NAV 80824	NABEGEHÄUSE	HUB HOUSING	BOÎTE DE MOYEU
3	1	80984	BESKYTTELSKAPPE	SCHEIBE	WASHER	RONDELLE
4	1	80986	STÅLTÆTNING FOR STARCO NAV 80824	DICHTUNG	SEAL	JOINTS
5	1	23503	LEJE TYPE 30209- FL 45-8	LAGER	BEARING	FIXATION
6	1	23502	LEJE TYPE 30206- FL 45-8	LAGER	BEARING	FIXATION
7	1	80827	KRONEMÅTRIK FOR ADR NAV 80824	MUTTER	NUT	ÉCROU
8	1	80828	SPLIT FOR ADR NAV 80824	SPLINTE	SPLIT PIN	GOUPILLE
9	1	80832	NAVKAPSEL FOR ADR NAV 80824	NABEKAPSEL	HUB CAP	BOÎTE DE MOYEU
10	1	80985	SMØRENIPPEL M8x1,25	SCHMIERNIPPEL	GREASE NIPPLE	GRAISSEUR

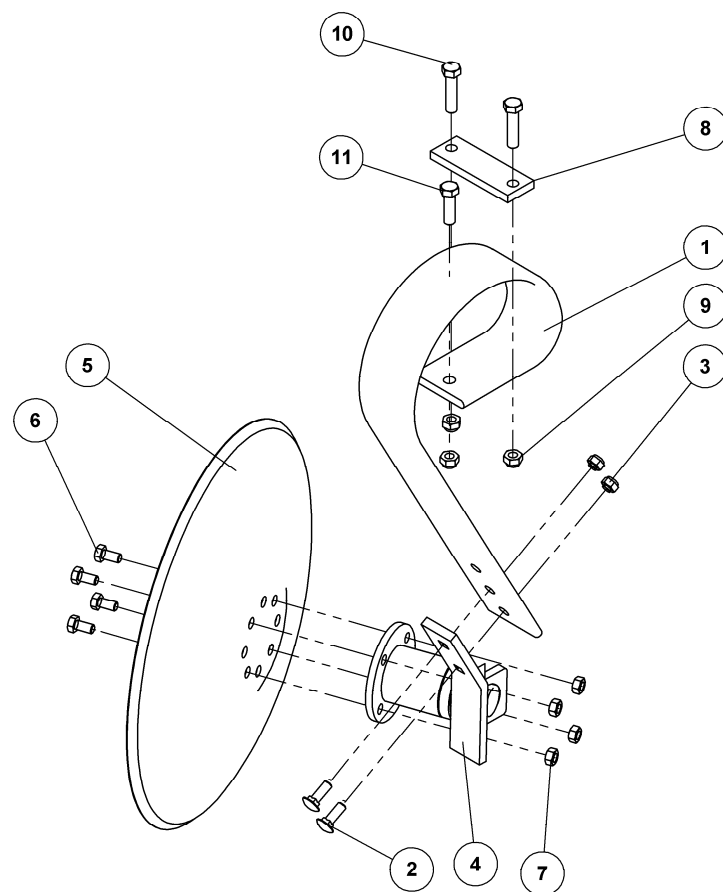
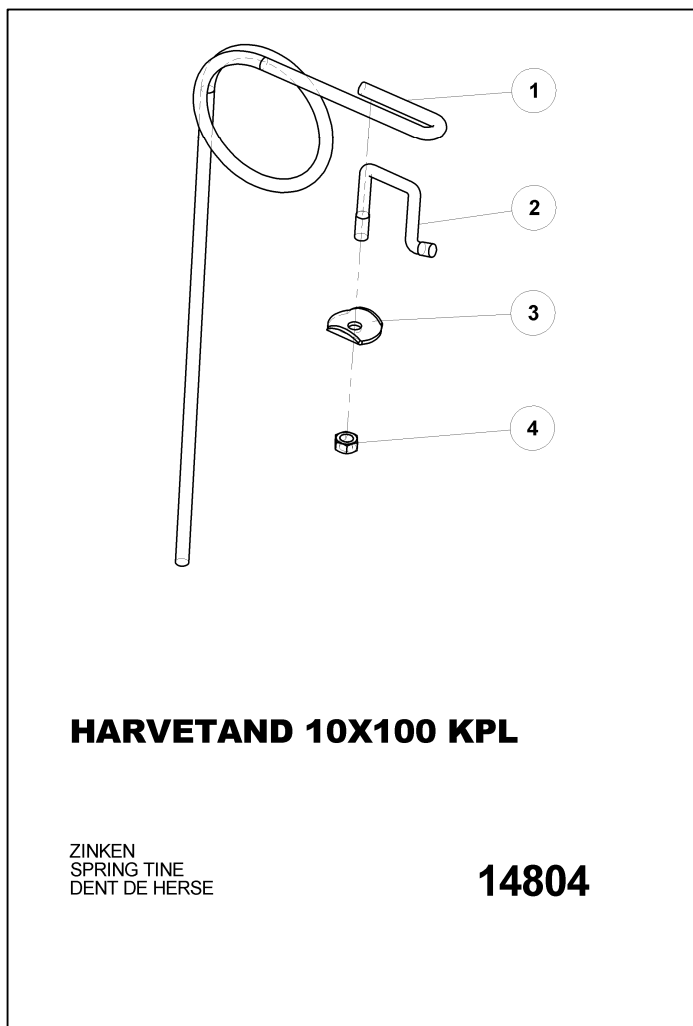



LAMELTAND 80MM BRED KPL.

MED TALLERKEN

91696

CB-ZINKEN
CRACKERBOARD TINE
DENT CB

Pos.	Qty.	Part nr.	Benævnelse	Bezeichnung	Description	Designation
1	1	91707	LAMELTAND LANG 3 HULS 80MM BRED	CB-ZINKEN	CB - TINE	DENT DE CB
2	2	92381	BOLT 10X30 GALV. 8.8 (BRÆDDEBOLT)	SCHRAUBE	BOARD BOLT	BOULON
3	2	92049	MØTRIK M10 SELVLÅS. GLV.8	MUTTER	SELF-LOCKING NUT	ÉCROU
4	1	80470	NAV TIL SIDETALLERKEN KPL.	NABE	HUB	MOYEU
5	1	75261	TALLERKEN Ø460x4 GLAT	SCHEIBE	DISC	RONDELLE
6	4	92273	BOLT 10x20 8.8 GALV. (SÆTBOLT)	SCHRAUBE	SET SCREW	BOULON
7	4	92029	MØTRIK M10 GALV. kl.8	MUTTER	NUT	ÉCROU
8	1	80783	LASKE FOR LAMELTAND	LASCHE	PLATE	PLAQUE
9	3	92050	MØTRIK M12 SELVLÅS. GLV. 8	MUTTER SELBSTSCHLIESSEND	SELFLOCKING NUT	ÉCROU DE SÉCURITÉ
10	2	92297	BOLT 12x50 8.8 GALV.	SCHRAUBE	SCREW	BOULON
11	1	92296	BOLT 12x40 8.8 GALV.	SCHRAUBE	SCREW	BOULON



HARVETAND 10X100 KPL

14804

ZINKEN
SPRING TINE
DENT DE HERSE

Pos.	Qty.	Part nr.	Benævnelse	Bezeichnung	Description	Designation
1	1	14805	HARVETAND 10X100 INDV. x TÆTV.	ZINKEN	SPRING TINE	DENT DE HERSE
2	1	14801	DRAGEBÅND M10 X 58 KV.4.6 ELG.GULP	KLEMMBAND	U-BOLT	COLLIER DE SERRAGE
3	1	14802	SPÆNDEPL. F. EFTERHARVETAND	PLATTE	FASTENING PLATE	PLAQUE
4	1	92029	MØTRIK M10 GALV. kl.8	MUTTER	NUT	ÉCROU

Nav t/skive kpl. Ø35, nabe, hub, moyeu

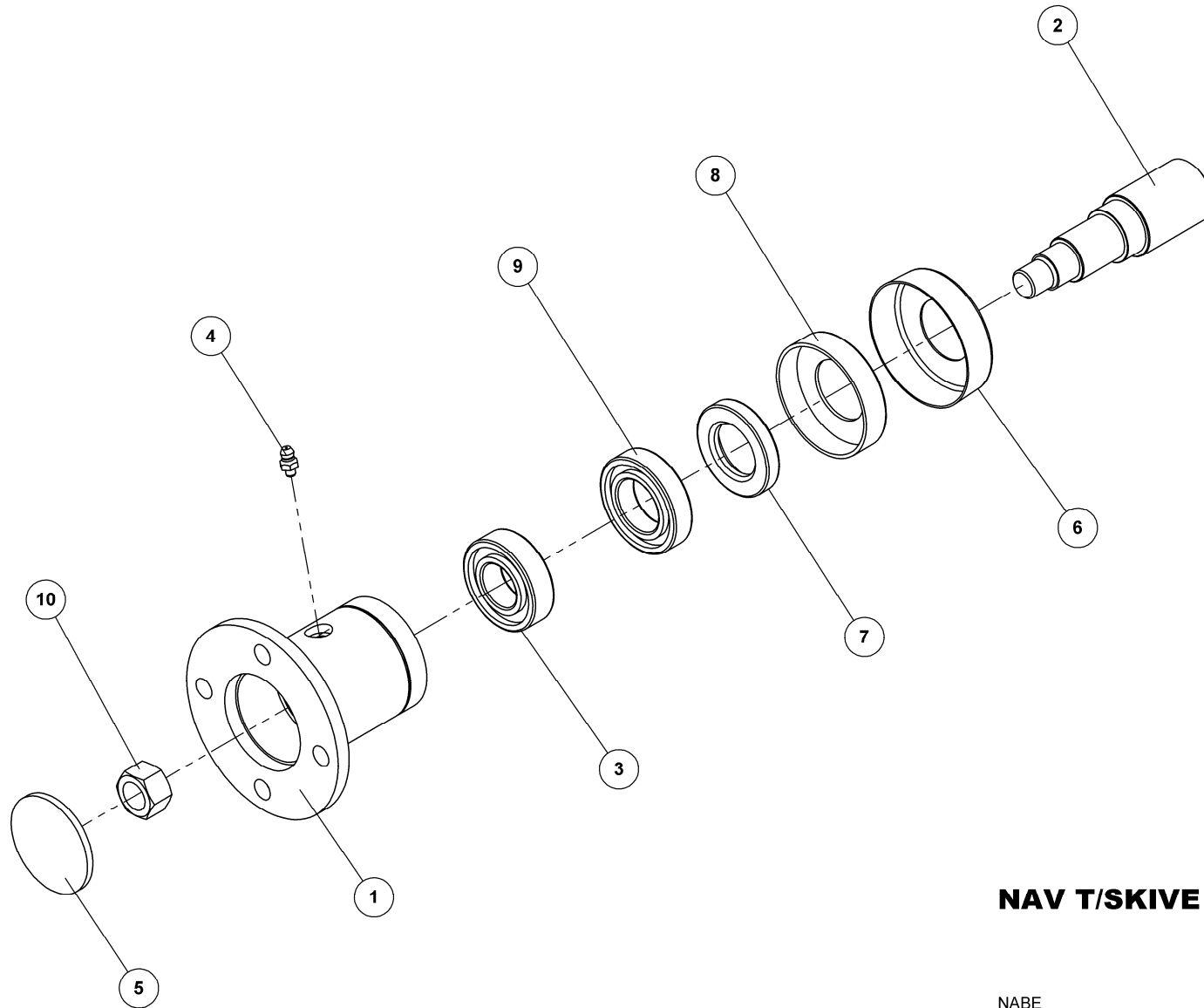

NAV T/SKIVE KPL. Ø35

NABE
HUB
MOYEU DE RONDELLE CPL.

76885



NAV T/SKIVE KPL. Ø35

76885

NABE
HUB
MOYEU DE RONDELLE CPL.

Pos.	Qty.	Part nr.	Benævnelse	Bezeichnung	Description	Designation
1	1	76887	NAVHUS TIL Ø35 AKSEL	NABEGEHÄUSE	HUB HOUSING	BOÎTE DE MOYEU
2	1	76888	AKSEL Ø35X121 TIL NAV	ACHSE	SHAFT	ARBRE
3	1	75272	KUGLELEJE 6205	LAGER	BEARING	FIXATION
4	1	75889	SMØRENIPPEL M6X1 K	SCHMIERNIPPEL	GREASE NIPPLE	GRAISSEUR
5	1	75891	GUMMISKIVE T/NAV 55.5x4	GUMMISCHEIBE	RUBBER WASHER FOR HUB	RONDELLE EN CAOUTCHOUC POUR MOYEU
6	1	76886	STØVKAPPE M. Ø35 MM HUL - STÅL	STAUBKAPPE FÜR NABE - STAHL	DUST CAP FOR HUB, STEEL	CACHE-POUSSIÈRE POUR MOYEU - ACIER
7	1	76890	TÆTNINGSRING 55/35/10 T/NAV	DICHTUNGSRING	SEAL	BAGUE D'ÉTANCHÉITÉ
8	1	75892	STØVKAPPE T/NAV PLAST	STAUBKAPPE FÜR NABE - PLASTIK	DUST CAP FOR HUB, PLASTIC	CACHE-POUSSIÈRE POUR MOYEU - PLASTIQUE
9	1	75273	KUGLELEJE 6006	LAGER	BEARING	FIXATION
10	1	92031	MØTRIK M16 GALV. kl.8	MUTTER	NUT	ÉCROU

Efterløber 600 cm kpl., n chlaufer, roller t-ring, traine anneau-t

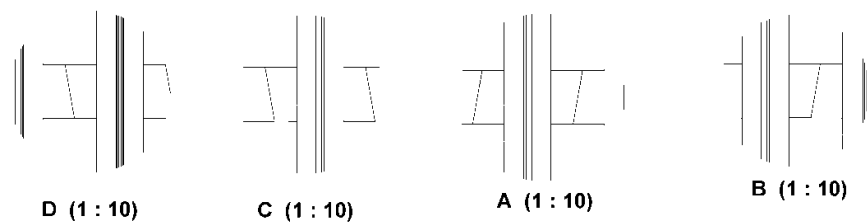
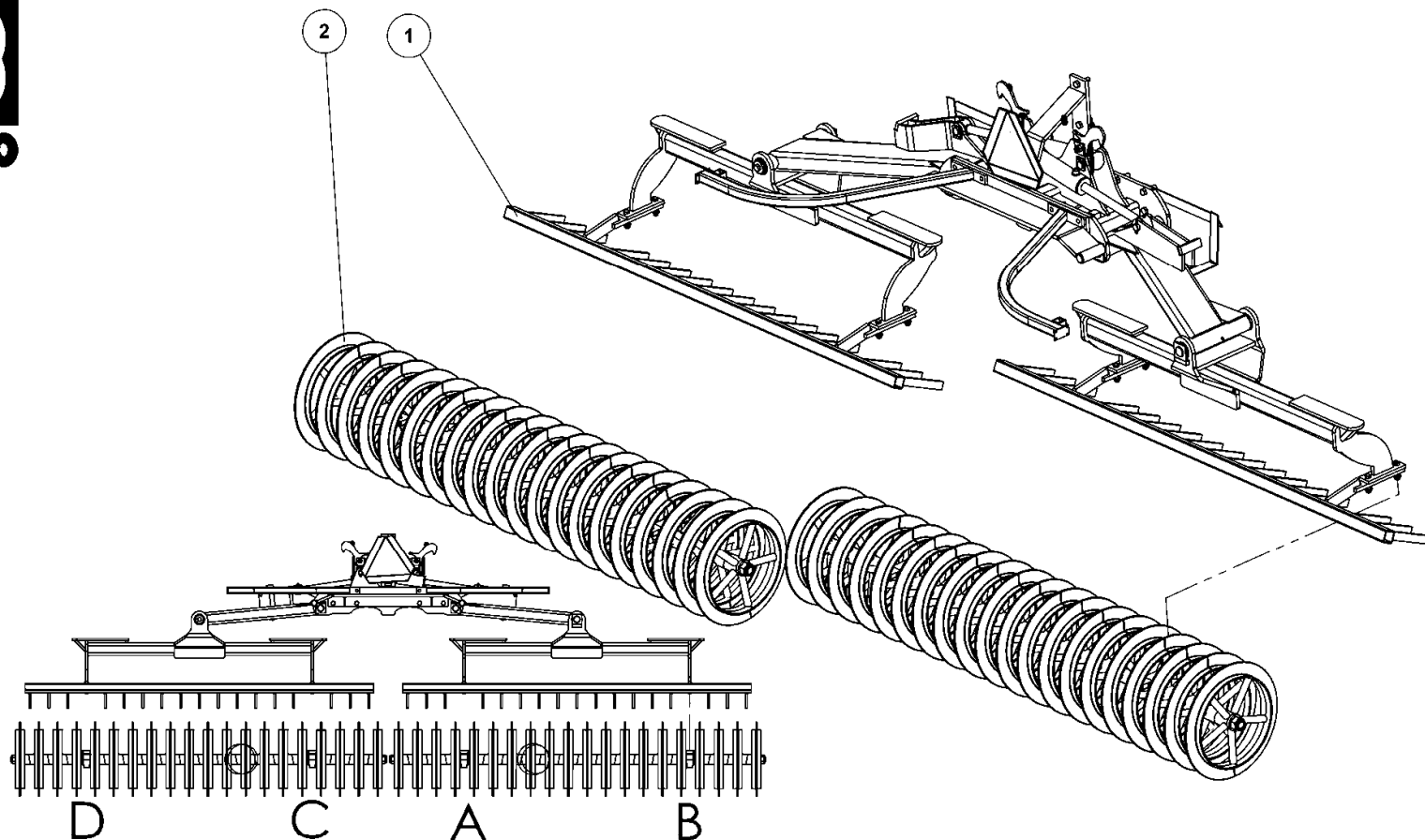

EFTERL BER 600 CM KPL. ENKELT

80051



EFTERLØBER 600 CM KPL. ENKELT

80051

Pos.	Qty.	Part nr.	Benævnelse	Bezeichnung	Description	Designation
1	1	80068	EFTERLØBER 600 CM U. T-RINGE	NACHLÄUFER OHNE T-RINGE	ROLLER WITHOUT T-RING	TRAINE PREPOSITION ANNEAU-T
2	2	82914	SÆT RINGE PÅ AKSEL 2007 600X60	SATZ RINGE FÜR DIE ACHSE	SHAFT RING SET	ANNEAUX SUR ARBRE

Efterløber 500 cm kpl.

80050

Nächlaufer
Roller, T-ring
Traine, anneau-t

Pos.	Qty.	Part nr.	Benævnelse	Bezeichnung	Description	Designation
1	1	80067	Efterløber 500 cm u. t-ringe	Nachläufer ohne T-ringe	Roller without t-ring	Traine preposition anneau-t
2	2	82915	Sæt ringe på aksel 250x60	Satz Ringe für die Achse	Shaft ring set	Anneaux sur arbre

Efterløber 400cm kpl.

80049

Nächlaufer
Roller, T-ring
Traine, anneau-t

Pos.	Qty.	Part nr.	Benævnelse	Bezeichnung	Description	Designation
1	1	80066	Efterløber 400 cm u. t-ringe	Nachläufer ohne T-ringe	Roller without t-ring	Traine preposition anneau-t
2	2	82916	Sæt ringe på aksel 200x60	Satz Ringe für die Achse	Shaft ring set	Anneaux sur arbre

Efterløber 600 cm u. t-ringe, nAchläufer ohne t-ringe, roller without t-ring, traine preposition anneau-t

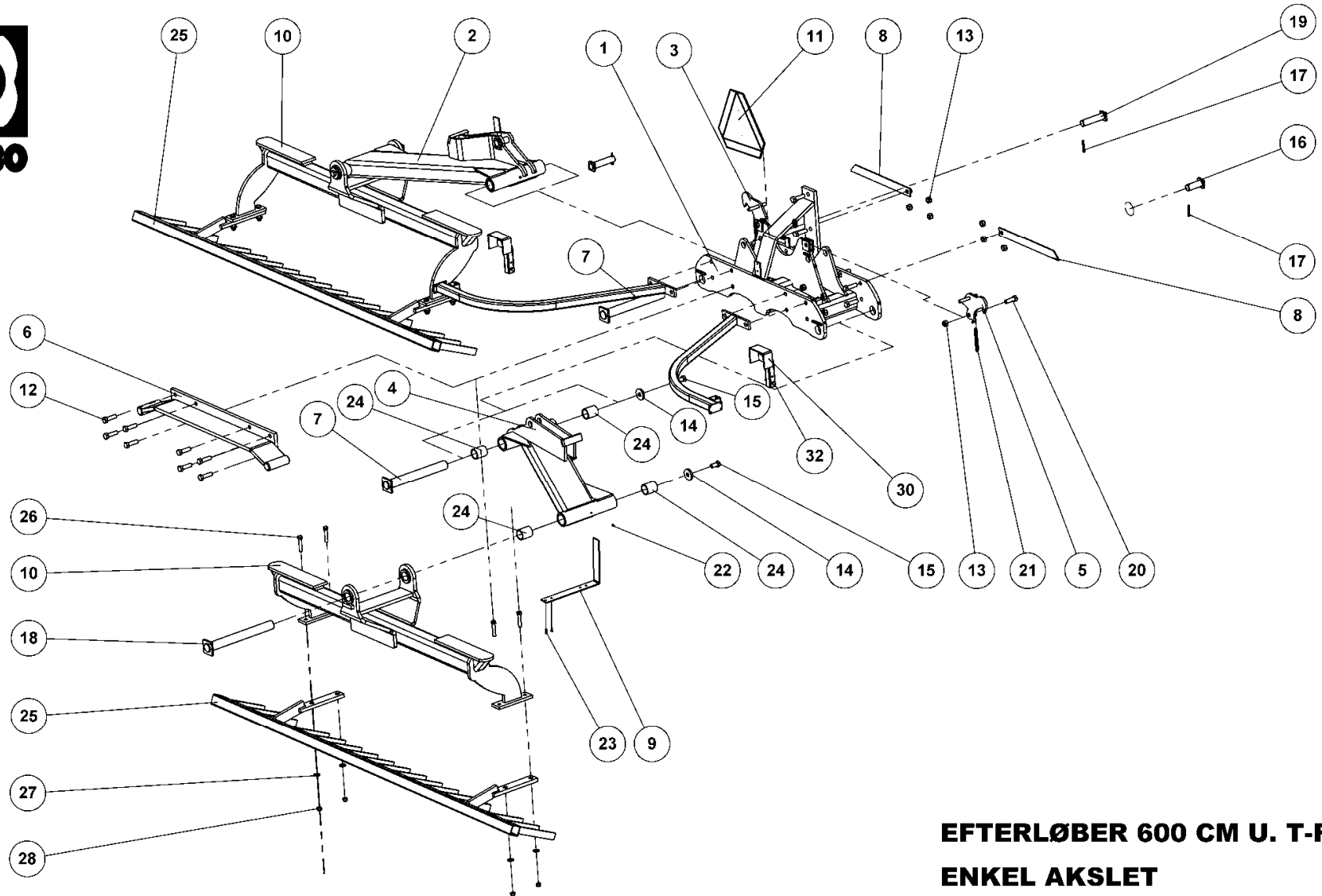

EFTERLØBER 600 CM U. T-RINGE
ENKEL AKSLET

NACHLÄUFER OHNE T-RINGE
ROLLER WITHOUT T-RING
TRAINE PREPOSITION ANNEAU-T

80068



EFTERLØBER 600 CM U. T-RINGE

ENKEL AKSLET

80068

NACHLÄUFER OHNE T-RINGE
ROLLER WITHOUT T-RING
TRAINE PREPOSITION ANNEAU-T

Pos.	Qty.	Part nr.	Benævnelse	Bezeichnung	Description	Designation
1	1	74440	EFTERLØBEROPHÆNG	NACHLAUFERAUFHÄNGUNG	ROLLER LINKAGE	SUSPENSION DE TRÂINE
2	1	80724	ARM TIL EFTERLØBER 600, VENSTRE	ARM FÜR DEN NACHLÄUFER	ARM FOR TOWED ROLLER	BRAS POUR TRÂINE
3	1	74578	TRANSPORTKROG HYDR.	TRANSPORTSICHERUNG	TRANSPORT LOCK	SYSTÈME DE VÉROUILLAGE DE TRANSPORT
4	1	80725	ARM TIL EFTERLØBER 600, HØJRE	ARM FÜR DEN NACHLÄUFER	ARM FOR TOWED ROLLER	BRAS POUR TRÂINE
5	1	74579	TRANSPORTKROG HYDR.	TRANSPORTSICHERUNG	TRANSPORT LOCK	SYSTÈME DE VÉROUILLAGE DE TRANSPORT
6	1	80726	TRANSPORTLÅS KPL.	TRANSPORTSICHERUNG	TRANSPORT LOCK	SYSTÈME DE VÉROUILLAGE DE TRANSPORT
7	2	74306	NAGLE F Ø50X413(428)M20 ind.	BOLZEN	PIN	AXE
8	2	74443	AXR-H DYBDEMARKERING 500+800	EIEFENREGULIERUNG	DEPTH ADJUSTMENT	REGLAGE DE PROFOND
9	2	80709	DYBDEMARKERINGSBØJLE - BOGIE	INDIKATOR	INDICATOR	INDICATEUR
10	2	80439	EFTERLØBERRAMME ENKELT	RAHME	FRAME	CADRE
11	1	34224	ADVARSELSREFLEKS KPL. - STOR	WARN DREIECK	WARNING TRIANGLE	ECRITEAU AVERTISSEUR
12	18	92342	BOLT 20x70 8.8 GALV.	SCHRAUBE	SCREW	BOULON
13	20	92052	MØTRIK M 20 SELVLÅS. GALV. 8	MUTTER SELBSTGESICHERT	SELF-LOCKING NUT	ÉCROU DE SÉCURITÉ
14	4	74529	SKIVE Ø21-Ø69-10	UNTERLEGSSCHEIBE	WASHER	RONDELLE DE SERRAGE
15	4	92349	BOLT 20x40 8.8 GALV. (SÆTBOLT)	SCHRAUBE	SCREW	BOULON
16	2	74308	NAGLE F Ø35X80(108)	BOLZEN	PIN	AXE
17	4	90677	SPLIT 8X50 MM GALV.	SPLIT	SPLIT PIN	GOUPILLE
18	2	74319	NAGLE F Ø50X452	BOLZEN	PIN	AXE
19	2	74309	NAGLE F Ø35X140(163)	BOLZEN	PIN	AXE
20	2	92334	BOLT 20x60 8.8 GALV.	SCHRAUBE	SCREW	BOULON
21	2	60411	FJEDER 1.5X15X60 38V GALV.	FEDER	SPRING	RESSORT
22	4	90721	SMØRENIPPEL M8x1	SCHMIERNIPPEL	GREASE NIPPLE	GRAISSEUR
23	4	92250	BOLT 6x20 8.8 GALV.	SCHRAUBE	SCREW	BOULON
24	8	59300	BRONCEBØSNING Ø60/Ø50 X 70	DOUILLE EN BRONZE	BRONZE BUSHING	BRONZEBUCHSE
25	2	80466	AFSKRABERBOM KPL. 300X60	ABSTREIFER	SCRAPER	SYSTÈME DE RACLAGE
26	8	92320	BOLT 16x80 8.8 GALV.	SCHRAUBE	SCREW	BOULON
27	8	90663	SKIVE Ø17-Ø35-2	SCHEIBE	WASHER	RONDELLE
28	8	92051	MØTRIK M16 SELVLÅS. GLV. 8	MUTTER	SELF-LOCKING NUT	ÉCROU
29	2	80347	LYGTEHOLDER VENSTRE+HØJRE	LEUCHTSTANGE	LIGHT BAR	DISPOSITIF DE PHARES
30	2	71454	LYGTESTANDER FÆLLES	LEUCHTSTÄNDER	LIGHT STAND	BÂTON DES LUMIÈRES
31	2	92050	MØTRIK M12 SELVLÅS. GLV. 8	MUTTER SELBSTSCHLIESSEND	SELFLOCKING NUT	ÉCROU DE SÉCURITÉ
32	2	92299	BOLT 12x70 8.8 GALV.	SCHRAUBE	SCREW	BOULON

Efterløber 400/500 cm u. t-ringe. Nachläufer ohne T-ring, Roller without t-ring, Traine preposition anneau-t

80063/80064

Pos.	Qty.	Part nr.	Benævnelse	Bezeichnung	Description	Designation
3	1	80442	Arm til efterløber 500, venstre	Arm, links	Arm, left	Bras, gauche
5	1	80443	Arm til efterløber 500, højre	Arm, rechts	Arm, right	Bras, droite
25	2	80487	Afskraberbom 500 kpl. 250x60	Abstreifer	Scraper	Système de serrage
3	1	80440	Arm til efterløber 400, venstre	Arm, links	Arm, left	Bras, gauche
5	1	80441	Arm til efterløber 400, højre	Arm, rechts	Arm, right	Bras, droite
25	2	80598	Afskraberbom 400 kpl. 200x60	Abstreifer	Scraper	Système de serrage

Sæt ringe på aksel 300x60, satz ringe für die achse, shaft ring set, anneaux sur arbre

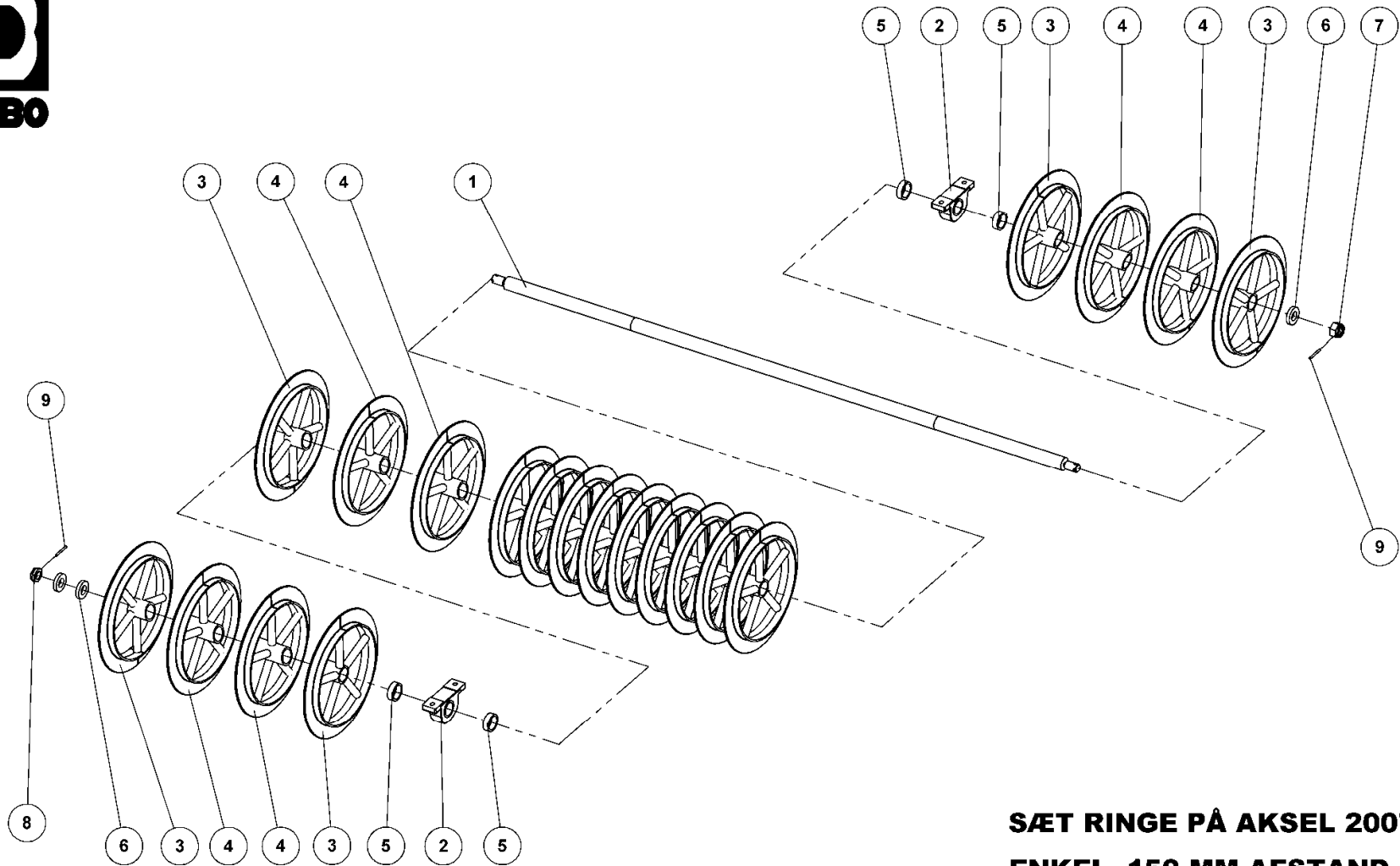

**SÆT RINGE PÅ AKSEL 2007 600X60
ENKEL, 150 MM AFSTAND**

SATZ RINGE FÜR DIE ACHSE
SHAFT RING SET
ANNEAUX SUR ARBRE

82914



SÆT RINGE PÅ AKSEL 2007 600X60 ENKEL, 150 MM AFSTAND

82914

SATZ RINGE FÜR DIE ACHSE
SHAFT RING SET
ANNEAUX SUR ARBRE

Pos.	Qty.	Part nr.	Benævnelse	Bezeichnung	Description	Designation
1	1	82937	AKSEL MED M39 L=2854 MM	WELLE	SHAFT	ARBRE
2	2	53290	KOMPLET STÅLEJE 60 MM	KOMPLETTES STEHLAGER	COMPLETE STEEL BEARING	PALIER COMPLET
3	6	82903	T-RING 600MM - 150 MM ENDE 2007	T-RING	T-RING	ANNEAU-T
4	14	82902	T-RING 600 MM - 150 MM MIDT 2007	T-RING	T-RING	ANNEAU-T
5	4	93130002590L90	AFSTANDSSTYKKE Ø80XØ63 L=25MM	ABSTANDSSTÜCK	SPACER	ENTRETOISE
6	2	72264	TOPSKIVE TIL CENTERNAGLE	SCHLEIBE FÜR ZENTRALNAGEL	TOP WASHER FOR CENTER PIN	RONDELLE DE SOMMET POUR MOYEU CENTRAL
7	2	72384	AKSELMØTRIK M39x3, NV 60 GLV. KI.8	ACHSENMUTTER	SHAFT NUT	ÉCROU D'ARBRE
8	2	90688	RØRSTIFT Ø 6X60 MM	ROHRSTIFT	SPLIT PIN	AXE TUBULAIRE

Pos	Qty.	Part nr.	Benævnelse	Bezeichnung	Description	Designation
			Sæt ringe på aksel 500x60 Satz ringe für die achse Shaft ring set Anneaux sur arbre			82915
1	1	82938	Aksel med M39 L=2554 mm	Welle	Shaft	Arbre
4	12	82902	T-RING 600MM – 150 MIDT 2007	T-RING	T-RING	ANNEAU-T
3	6	82903	T-RING 600MM – 150 ENDE 2007	T-RING	T-RING	ANNEAU-T

Pos	Qty	Part nr.	Benævnelse	Bezeichnung	Description	Designation
			Sæt ringe på aksel 400x60 Satz ringe für die achse Shaft ring set Anneaux sur arbre			82916
1	1	82939	Aksel med M39 L=2254 mm	Welle	Shaft	Arbre
4	10	82902	T-RING 600MM – 150 MIDT 2007	T-RING	T-RING	ANNEAU-T
3	6	82903	T-RING 600MM – 150 ENDE 2007	T-RING	T-RING	ANNEAU-T

Efterløber bogie 600 cm kpl., n chlauf r, roller t-ring, traine anneau-t

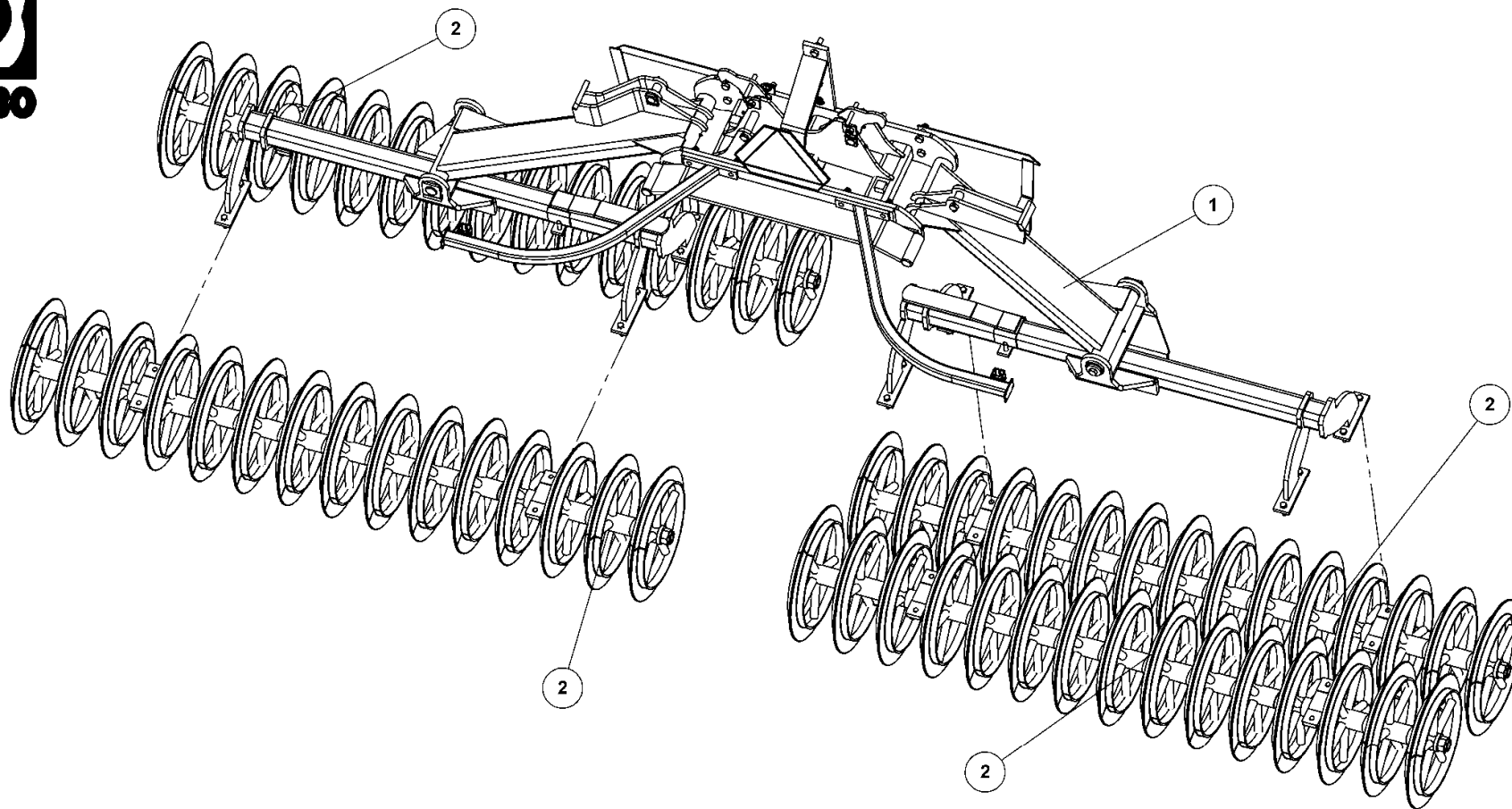

EFTERL BER 600 CM KPL. BOOGIE

NACHL UFER
ROLLER
TRAIN 

80055



EFTERLØBER 600 CM KPL. BOOGIE

80055

NACHLÄUFER
ROLLER
TRAINE

Pos.	Qty.	Part nr.	Benævnelse	Bezeichnung	Description	Designation
1	1	80057	EFTERLØBER 600 CM U. T-RINGE BOGIE	NACHLÄUFER OHNE T-RINGE	ROLLER WITHOUT T-RING	TRAINE PREPOSITION ANNEAU-T
2	4	82911	SÆT RINGE PÅ AKSEL 2007 600X60	SATZ RINGE FÜR DIE ACHSE	SHAFT RING SET	ANNEAUX SUR ARBRE

Efterløber 400/500 cm kpl.

DOBBELT PAKKER

80053/80054

Nächläufer
Roller, T-ring
Traine, anneau-t

Pos.	Qty.	Part nr.	Benævnelse	Bezeichnung	Description	Designation
1	1	80056	Efterløber 500 cm u. t-ringe	Nachläufer ohne T-ringe	Roller without t-ring	Traine preposition anneau-t
2	4	82912	Sæt ringe på aksel 500x60	Satz Ringe für die Achse	Shaft ring set	Anneaux sur arbre
1	1	80052	Efterløber 400 cm u. t-ringe	Nachläufer ohne T-ringe	Roller without t-ring	Traine preposition anneau-t
2	4	82913	Sæt ringe på aksel 400x60	Satz Ringe für die Achse	Shaft ring set	Anneaux sur arbre

Efterløber 600 cm u. t-ringe, nachläufer ohne t-ring, roller without t-ring, traine preposition anneau-t

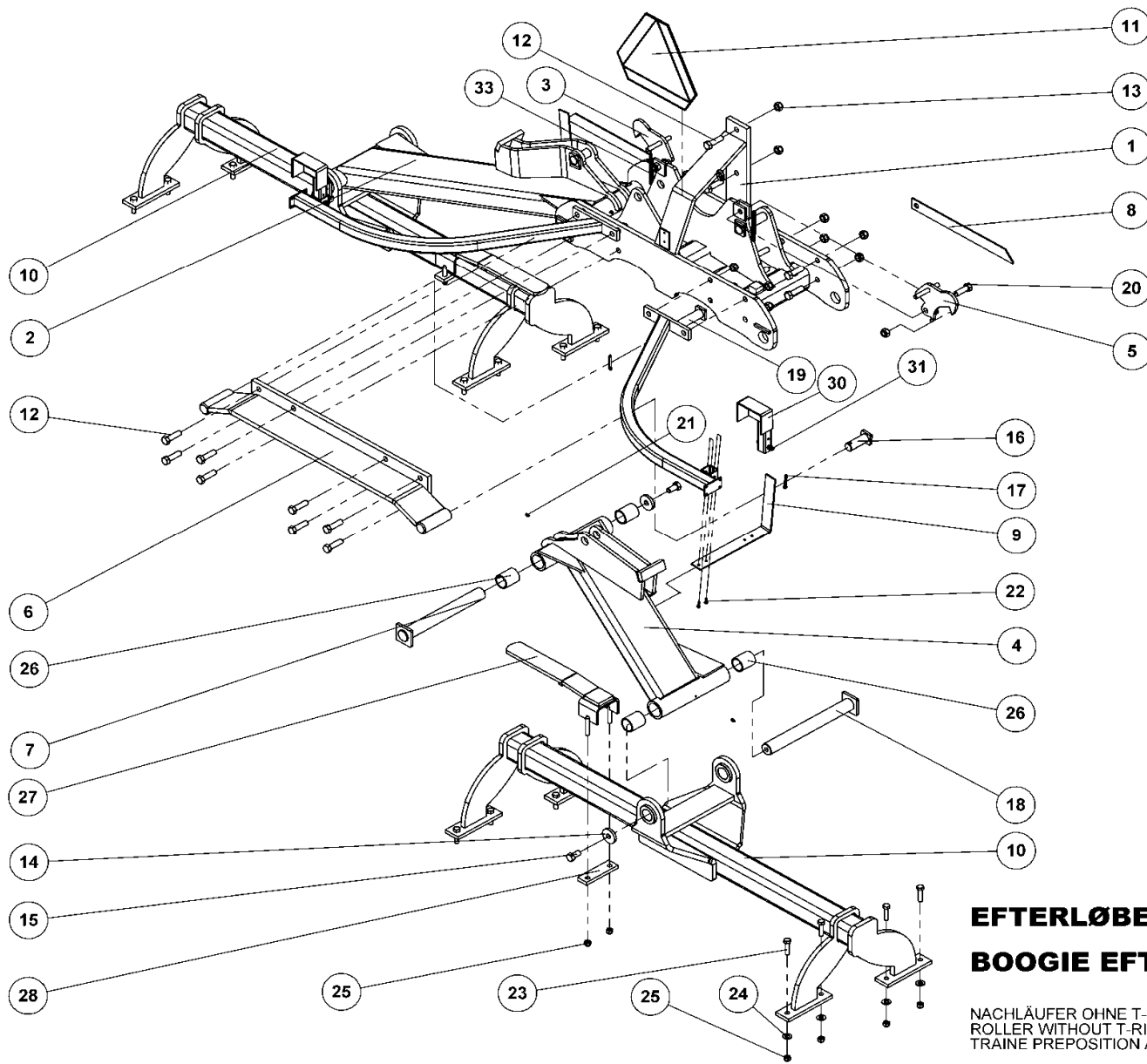

EFTERLØBER 600 CM U. T-RINGE
BOOGIE EFTERLØBER

NACHLÄUFER OHNE T-RINGE
 ROLLER WITHOUT T-RING
 TRAIINE PREPOSITION ANNEAU-T

80057



EFTERLØBER 600 CM U. T-RINGE

BOOGIE EFTERLØBER

80057

NACHLÄUFER OHNE T-RINGE
 ROLLER WITHOUT T-RING
 TRAIINE PREPOSITION ANNEAU-T

Pos.	Qty.	Part nr.	Benævnelse	Bezeichnung	Description	Designation
1	1	74440	EFTERLØBEROPHÆNG	NACHLÄUFERAUFHÄNGUNG	ROLLER LINKAGE	SUSPENSION DE TRAIINE
2	1	80724	ARM TIL EFTERLØBER 600, VENSTRE	ARM FÜR DEN NACHLÄUFER	ARM FOR TOWED ROLLER	BRAS POUR TRAIINE
3	1	74578	TRANSPORTKROG HYDR.	TRANSPORTSICHERUNG	TRANSPORT LOCK	SYSTÈME DE VEROUILLAGE DE TRANSPORT
4	1	80725	ARM TIL EFTERLØBER 600, HØJRE	ARM FÜR DEN NACHLÄUFER	ARM FOR TOWED ROLLER	BRAS POUR TRAIINE
5	1	74579	TRANSPORTKROG HYDR.	TRANSPORTSICHERUNG	TRANSPORT LOCK	SYSTÈME DE VEROUILLAGE DE TRANSPORT
6	1	80726	TRANSPORTLÅS KPL.	TRANSPORTSICHERUNG	TRANSPORT LOCK	SYSTÈME DE VEROUILLAGE DE TRANSPORT
7	2	74306	NAGLE F Ø50X413(428)M20 ind.	BOLZEN	PIN	AXE
8	2	74443	AXR-H DYBDEMARKERING 500+600	EIEFFENREGULIERUNG	DEPTH ADJUSTMENT	RÉGLAGE DE PROFOND
9	2	80709	DYBDEMARKERINGSBØJLE - BOGIE	INDIKATOR	INDICATOR	INDICATEUR
10	2	80449	EFTERLØBERRAMME BOGIE	RAHME	FRAME	CADRE
11	1	34224	ADVARSELSREFLEKS KPL., STOR	WARN DREIECK	WARNING TRIANGLE	ÉCRITEAU AVERTISSEUR
12	18	92342	BOLT 20x70 8.8 GALV.	SCHRAUBE	SCREW	BOULON
13	20	92052	MØTRIK M 20 SELVLÅS GALV. 8	MUTTER SELBSTGESICHERT	SELF-LOCKING NUT	ÉCROU DE SÉCURITÉ
14	4	74529	SKIVE Ø21-Ø69-10	UNTERLEGSCHIEBE	WASHER	RONDELLE DE SERRAGE
15	4	92349	BOLT 20x40 8.8 GALV. (SÆTBOLT)	SCHRAUBE	SCREW	BOULON
16	2	74308	NAGLE F Ø35X80(108)	BOLZEN	PIN	AXE
17	4	90677	SPLIT 8X50 MM GALV.	SPLINT	SPLIT PIN	GOUPILLE
18	2	74319	NAGLE F Ø50X452	BOLZEN	PIN	AXE
19	2	74309	NAGLE F Ø35X140(163)	BOLZEN	PIN	AXE
20	2	92334	BOLT 20x60 8.8 GALV.	SCHRAUBE	SCREW	BOULON
21	4	90721	SMØRENIPPEL M8x1	SCHMIERNIPPEL	GREASE NIPPLE	GRAISSEUR
22	4	92250	BOLT 6x20 8.8 GALV.	SCHRAUBE	SCREW	BOULON
23	16	92318	BOLT 18x80 8.8 GALV.	SCHRAUBE	SCREW	BOULON
24	16	90663	SKIVE Ø17-Ø35-2	SCHIEBE	WASHER	RONDELLE
25	20	92051	MØTRIK M16 SELVLÅS GLV. 8	MUTTER	SELF-LOCKING NUT	ÉCROU
26	8	59300	BRONCEBØSNING Ø60/Ø50 X 70	DOUILLE EN BRONZE	BRONZE BUSHING	BRONZEBUCHSE
27	2	80707	BESLAG FOR KLAP	BESCHLAG	MOUNTING PLATE	FIXATION
28	2	14401	SPÆNDEPLADE Ø17,5-102,5-50X15-170	PLATTE	PLATE	PLAQUE
29	2	80351	LYGTEHOLDER VENSTRE+HØJRE	LEUCHTSTANGE	LIGHT BAR	DISPOSITIF DE PHARES
30	2	71454	LYGTESTANDER FÆLLES	LEUCHTSTANDER	LIGHT STAND	BÂTON DES LUMIÈRES
31	2	92299	BOLT 12x70 8.8 GALV.	SCHRAUBE	SCREW	BOULON
32	2	92050	MØTRIK M12 SELVLÅS GLV. 8	MUTTER SELBSTSCHLIESSEND	SELFLOCKING NUT	ÉCROU DE SÉCURITÉ
33	2	60411	FJEDER 1.5X15X80 38V GALV.	FEDER	SPRING	RESSORT

Efterløber 400/500 cm u. t-ringe. DOBBELT PAKKER

80052/80056

Nächläufer ohne T-ring, Roller without t-ring, Traîne preposition anneau-t

Pos.	Qty.	Part nr.	Benævnelse	Bezeichnung	Description	Designation
3	1	80722	Arm til efterløber 500, venstre	Arm, links	Arm, left	Bras, gauche
5	1	80723	Arm til efterløber 500, højre	Arm, rechts	Arm, right	Bras, droite
2	2	91805	Cylinder 80/40X350, 500 efterløber	Cylinder	Cylinder	Verrin
3	1	80606	Arm til efterløber 400, venstre	Arm, links	Arm, left	Bras, gauche
5	1	80603	Arm til efterløber 400, højre	Arm, rechts	Arm, right	Bras, droite
2	2	91805	Cylinder 80/40X350, 400 efterløber	Cylinder	Cylinder	Verrin
10	2	80594	Efterløberamme bogie 4 meter	Rahme	Frame	Cadre

Sæt ringe på aksel 600x60, satz ringe für die achse, shaft ring set, anneaux sur arbre

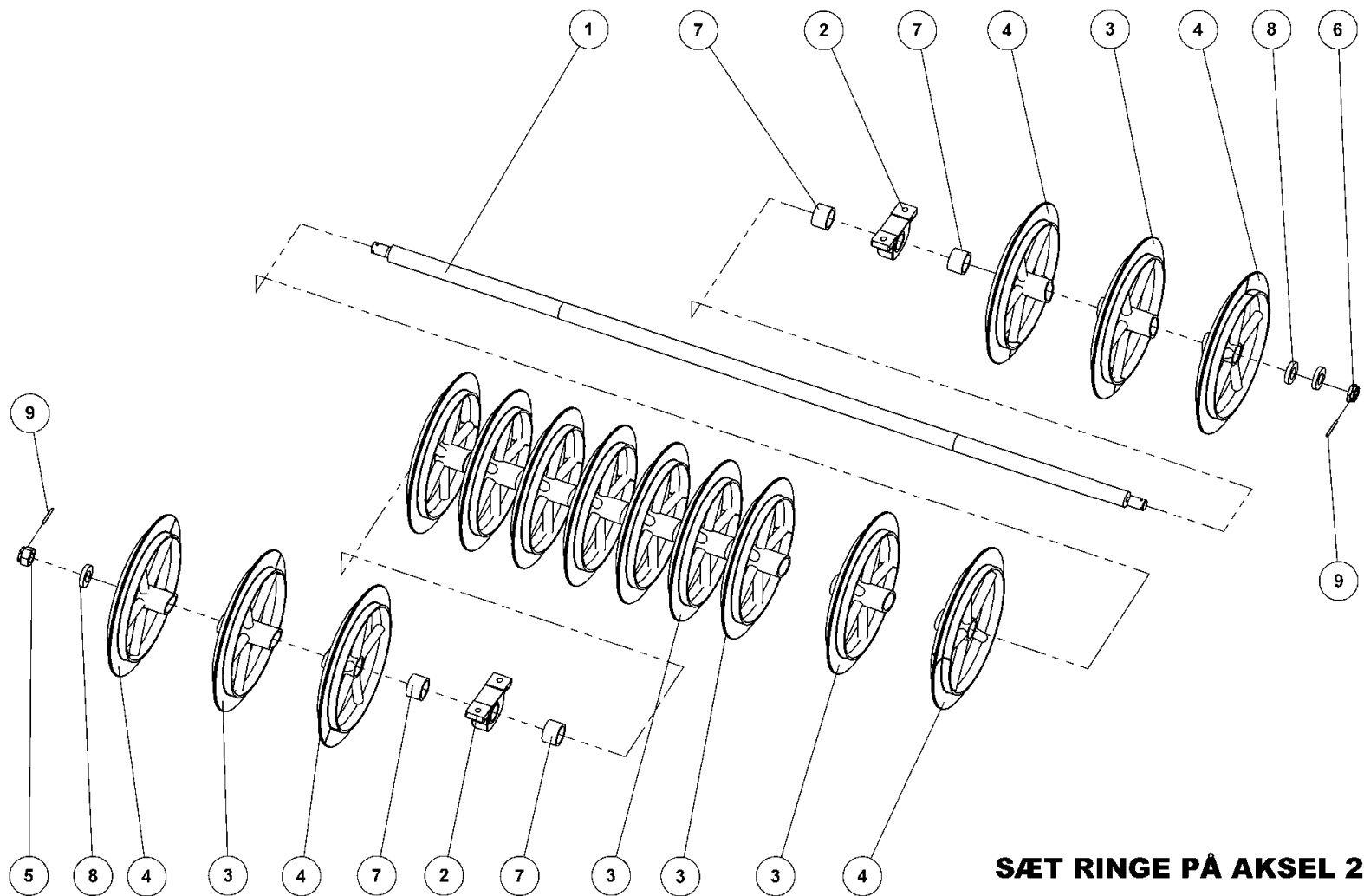

**SÆT RINGE PÅ AKSEL 2007 600X60
BOOGIE, 200 MM AFSTAND**

SATZ RINGE FÜR DIE ACHSE
SHAFT RING SET
ANNEAUX SUR ARBRE

82911



SÆT RINGE PÅ AKSEL 2007 600X60 BOOGIE, 200 MM AFSTAND

82911

SATZ RINGE FÜR DIE ACHSE
SHAFT RING SET
ANNEAUX SUR ARBRE

Pos.	Qty.	Part nr.	Benævneelse	Bezeichnung	Description	Designation
1	1	82930	AKSEL MED M39 L=2805 MM	WELLE	SHAFT	ARBRE
2	2	53290	KOMPLET STÅLEJE 60 MM	KOMPLETTES STEH LAGER	COMPLETE STEEL BEARING	PALIER COMPLET
3	9	82900	T-RING 600MM - 200 MM MIDT 2007	T-RING	T-RING	ANNEAU-T
4	6	82901	T-RING 600MM - 200 MM ENDE 2007	T-RING	T-RING	ANNEAU-T
5	1	72384	AKSELMØTRIK M39x3. NV 60 GLV. KI.8	ACHSENMUTTER	SHAFT NUT	ÉCROU D'ARBRE
6	1	92518	KRONEMØTRIK M39X3	ACHSENMUTTER	SHAFT NUT	ÉCROU D'ARBRE
7	4	93130005390L90LX	AFSTANDSSTYKKE Ø80XØ83 L=53MM	ABSTANDSSTÜCK	SPACER	ENTRETOISE
8	3	72264	TOPSKIVE TIL CENTERNAGLE	SCHEIBE FÜR ZENTRALNAGEL	TOP WASHER FOR CENTER PIN	RONDELLE DE SOMMET POUR MOYEU CENTRAL
9	2	90764	RØRSTIFT Ø 8X80 MM	ROHRSTIFT	SPLIT PIN	AXE TUBULAIRE

Sæt ringe på aksel 500x60

82912

Satz ringe für die achse
Shaft ring set
Anneaux sur arbre

.Pos	Qty.	Part nr.	Benævneelse	Bezeichnung	Description	Designation
1	1	82929	Aksel med M39 L=2405 mm	Welle	Shaft	Arbre
3	7	82900	T-RING 600MM – 200 MIDT 2007	T-RING	T-RING	ANNEAU-T
4	6	82901	T-RING 600MM – 200 ENDE 2007	T-RING	T-RING	ANNEAU-T

Pos	Qty	Part nr.	Benævneelse	Bezeichnung	Description	Designation
			Sæt ringe på aksel 400x60 Satz ringe für die achse Shaft ring set Anneaux sur arbre			82913
1	1	82928	Aksel med M39 L=2005 mm	Welle	Shaft	Arbre
3	5	82900	T-RING 600MM – 200 MIDT 2007	T-RING	T-RING	ANNEAU-T
4	6	82901	T-RING 600MM – 200 ENDE 2007	T-RING	T-RING	ANNEAU-T

Hydraulik
Hydraulik til hjulstel, rad gestell hydraulik, wheel frame hydraulic, cadre de roue, hydraulique

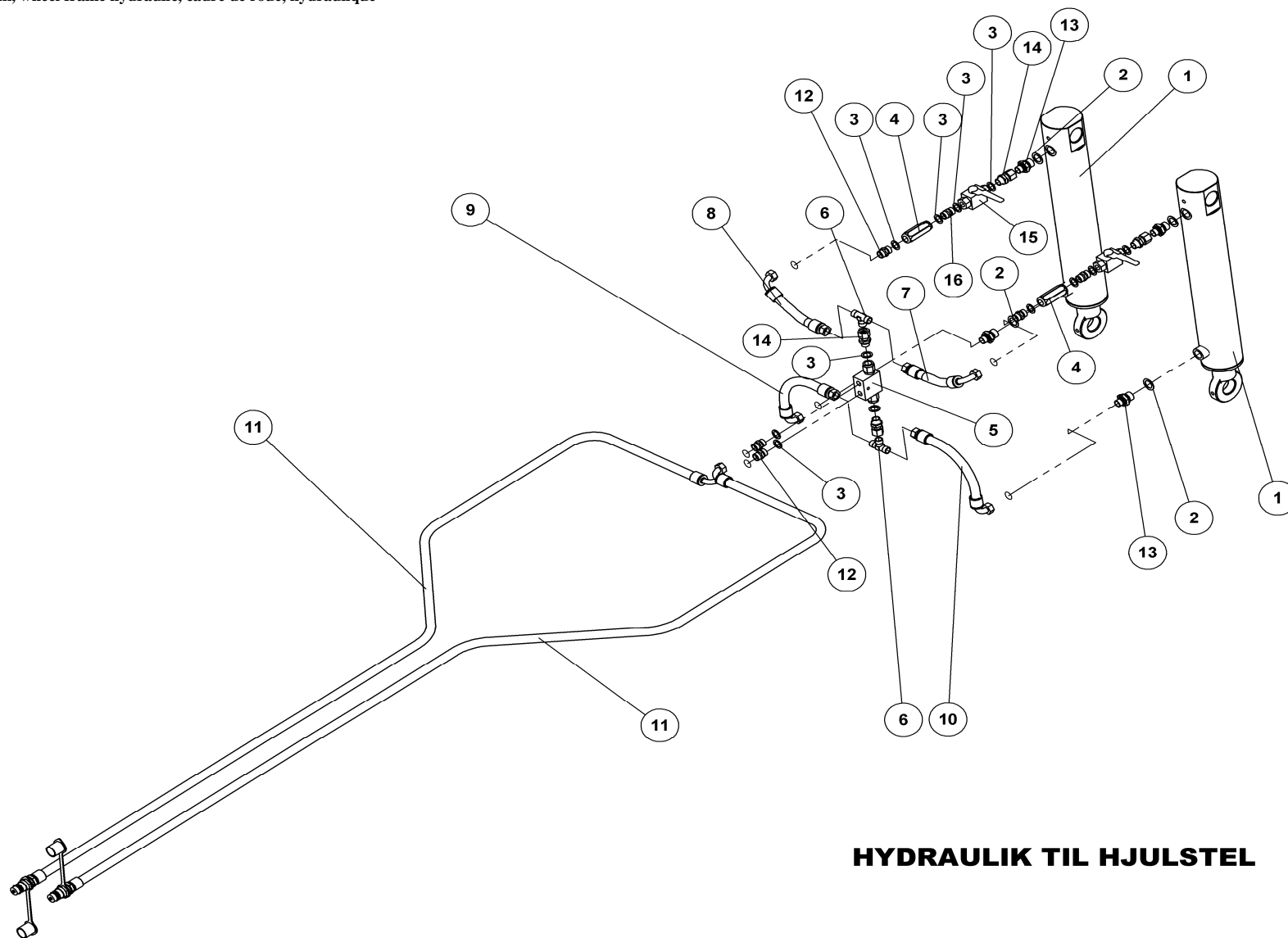

HYDRAULIK TIL HJULSTEL

RAD GESTELL HYDRAULIK
WHEEL FRAME HYDRAULIC
CADRE DE ROUE, HYDRAULIQUE

80537

side 38



HYDRAULIK TIL HJULSTEL

80537

RAD GESTELL HYDRAULIK
WHEEL FRAME HYDRAULIC
CADRE DE ROUE, HYDRAULIQUE

Pos.	Qty.	Part nr.	Benævnelse	Bezeichnung	Description	Designation
1	2	91810	CYLINDER 80/50X350	ZYLINDER	CYLINDER	VERRIN
2	4	91029	1/2" BONDED SEALS PAKRING	BONDED SEALS PACKRING	BONDED SEAL WASHER	JOINT BONDED SEALS
3	12	91028	3/8" BONDED SEALS PAKRING	BONDED SEALS PACKRING	BONDED SEAL WASHER	JOINT BONDED SEALS
4	2	91315	DRØVLE KONTRA 3/8" - 2.5 MM BLÆND	CLAPET DE BLOCAGE PILOTE	THROTTLE AND CHECK VALVE, CAP	DROSSEL KONTRA
5	1	51316	PILOTSTYRET KONTRAVENTIL 3/8 - DOBBELT	PILOTGESTEUERTES SPERRVENTIL DOBBELT	PILOT-OPERATED CHECK VALVE, DOUBLE	CLAPET DE BLOCAGE PILOTE DOUBLE
6	2	91006	T-STYKKE M18X1.5 P-TV 12L	T-STÜCK	T-PIECE	T-PIÈCE
7	2	80542	SLANGE M18 V + M18 L L=150 MM	SCHLAUCH	HOSE	TUYAU
8	1	80543	SLANGE M18 V + M18 L L=280 MM	SCHLAUCH	HOSE	TUYAU
9	1	80543	SLANGE M18 V + M18 L L=240 MM	SCHLAUCH	HOSE	TUYAU
10	2	80575	SLANGE HAN + M18 V L=5950 MM	SCHLAUCH	HOSE	TUYAU
11	4	91003	BRYSTNIPPEL M18 / 3/8" RG GALV.	VERSCHRAUBUNG	HEXAGON NIPPLE CONNECTOR	RACCORD DE JONCTIONS MÂLES
12	4	91073	BRYSTNIPPEL 1/2"RG/M18X1,5 GALV	VERSCHRAUBUNG	HEXAGON NIPPLE CONNECTOR	RACCORD DE JONCTIONS MÂLES
13	4	91113	LIGE FORSKR. P-EGES 12 LR-WD-SV	GERADE VERSCHRAUBUNG	STRAIGHT CONNECTION	JOINT DROIT
14	2	50573	VENTIL KH-R 3/8 NW10 ORSTA	KUGELHAHN	VALVE	VANETTE 3/8"
15	2	91002	BRYSTNIPPEL 3/8"RG / 3/8"RG GALV	VERSCHRAUBUNG	HEXAGON NIPPLE CONNECTOR	RACCORD DE JONCTIONS MÂLES

Hydraulik til dybdejustering, hydraulik tiefenregulierung, hydraulic depth adjustment, hydraulique réglage de profond

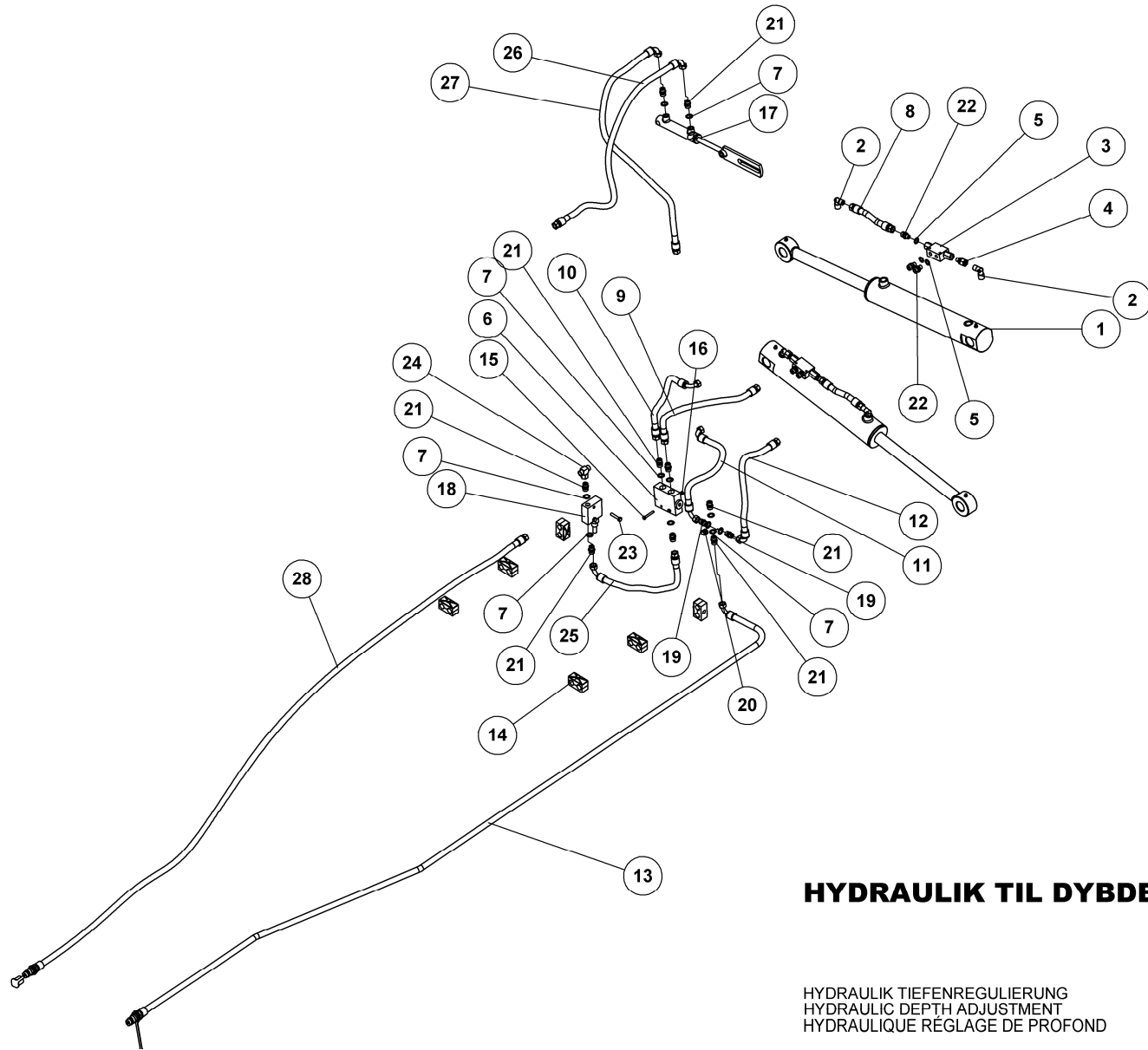

HYDRAULIK TIL DYBDEJUSTERING

HYDRAULIK TIEFENREGULIERUNG
HYDRAULIC DEPTH ADJUSTMENT
HYDRAULIQUE RÉGLAGE DE PROFOND

80538



HYDRAULIK TIL DYBDEJUSTERING

80538

HYDRAULIK TIEFENREGULIERUNG
HYDRAULIC DEPTH ADJUSTMENT
HYDRAULIQUE RÉGLAGE DE PROFOND

Pos.	Qty.	Part nr.	Benævnelse	Bezeichnung	Description	Designation
1	2	91805	Cylinder 80/40x350	ZYLINDER	CYLINDER	VERRIN
2	4	91082	VINKELFORSKR. P-WEV 12LR ½"K	WINKEL	CONNECTOR	ANGLE
3	2	51311	PILOTSTYRET KONTRAVENTIL 1/4 - DOBBELT	PILOTGESTEUERTES SPERRVENTIL DOPPELT	PILOT-OPERATED CHECK VALVE, DOUBLE	CLAPET DE BLOCAGE PILOTE DOUBLE
4	2	91114	LIGE FORSKRUNING 1/4"MALE / M18 FEMALE	GERADE VERSCHRAUBUNG	STRAIGHT CONNECTION	JOINT DROIT
5	6	91027	1/4" BONDED SEALS PAKRING	BONDED SEALS PACKRING	BONDED SEAL WASHER	JOINT BONDED SEALS
6	1	71241	MÆNGDEDELERVENTIL 50/50 10-20 L/MIN	KUGELHAHN	VALVE	VANETTE 3/8"
7	11	91028	3/8" BONDED SEALS PAKRING	BONDED SEALS PACKRING	BONDED SEAL WASHER	JOINT BONDED SEALS
8	2	80576	SLANGE M18 L + M18 L L=160 MM	SCHLAUCH	HOSE	TUYAU
9	1	80577	SLANGE M18 L + M18 L L=450 MM	SCHLAUCH	HOSE	TUYAU
10	1	80549	SLANGE M18 L + M18 V L=350 MM	SCHLAUCH	HOSE	TUYAU
11	1	80548	SLANGE M18 V + M18 V L=350 MM	SCHLAUCH	HOSE	TUYAU
12	1	80547	SLANGE M18 V + M18 L L=450 MM	SCHLAUCH	HOSE	TUYAU
13	1	80571	SLANGE HAN + M18 V L=6550 MM	SCHLAUCH	HOSE	TUYAU
14	6	91309	PLASTKLAMME, BOLT, DÆKPLADE 3/8" KPL	PLASTIK KLAMMER	PLASTIC HOSE CLAMP	CROCHET EN PLASTIQUE
15	2	92252	BOLT 6x45 8.8 GALV.	SCHRAUBE	SCREW	BOULON
16	2	92027	MØTRIK M6 GALV. kl.8	MUTTER	NUT	ÉCROU
17	1	77827	CYL. MED AFLANGHUL	ZYLINDER	RAN	VERRIN
18	1	71232	SEKVENSVENTIL 3/8" - 40 l/min	SEQUENSVENTIL	SEQUENCE VALVE	VALVE DE SÉQUENCE
19	2	91134	DRÆVL-BRYSTNIPPEL M18 X 3/8" - ¥1.0	DROSSEL-VERSCHRAUBUNG	THROTTLE, HEXAGON NIPPLE CONNECTOR	RACCORD DE JONCTIONS MÂLES-GRIVE
20	1	91093	SLUTPROP M/PAKNING 3/8"	SCHLUSSSTÖPSEL	END PLUG	BOUCHON DE FERMETURE
21	9	91003	BRYSTNIPPEL M18 / 3/8" RG GALV.	VERSCHRAUBUNG	HEXAGON NIPPLE CONNECTOR	RACCORD DE JONCTIONS MÂLES
22	6	91045	LIGE FORSKRUNING M18 x 1/4"	GERADE VERSCHRAUBUNG	STRAIGHT CONNECTION	JOINT DROIT
23	2	92264	BOLT 8x40 8x8 GALV.	SCHRAUBE	SCREW	BOULON
24	1	91024	STILB. T-FORSKR.Ø 12-L M/OR-D	WINKELBEFESTIGUNG	CONNECTOR	JOINT D'ANGLE
25	1	80656	SLANGE M18 L + M18 L L=200 MM	SCHLAUCH	HOSE	TUYAU
26	1	80657	SLANGE M18 V + M18 L L=600 MM	SCHLAUCH	HOSE	TUYAU
27	1	80658	SLANGE M18 V + M18 L L=700 MM	SCHLAUCH	HOSE	TUYAU
28	1	80659	SLANGE HAN + M18 L L=6400 MM	SCHLAUCH	HOSE	TUYAU

EFTERLØBER 600 CM KPL. BOGIE

80055

Nachläufer
Roller
Traine

Pos.	Qty.	Part nr.	Benævnelse	Bezeichnung	Description	Designation
1*	2	91845	Cylinder 90x50x350	Zylinder	Cylinder	Verrin

Hydraulik til opklap tall., hydraulik aus/zusammenklappen, hydraulic folding, hydraulique de repliage

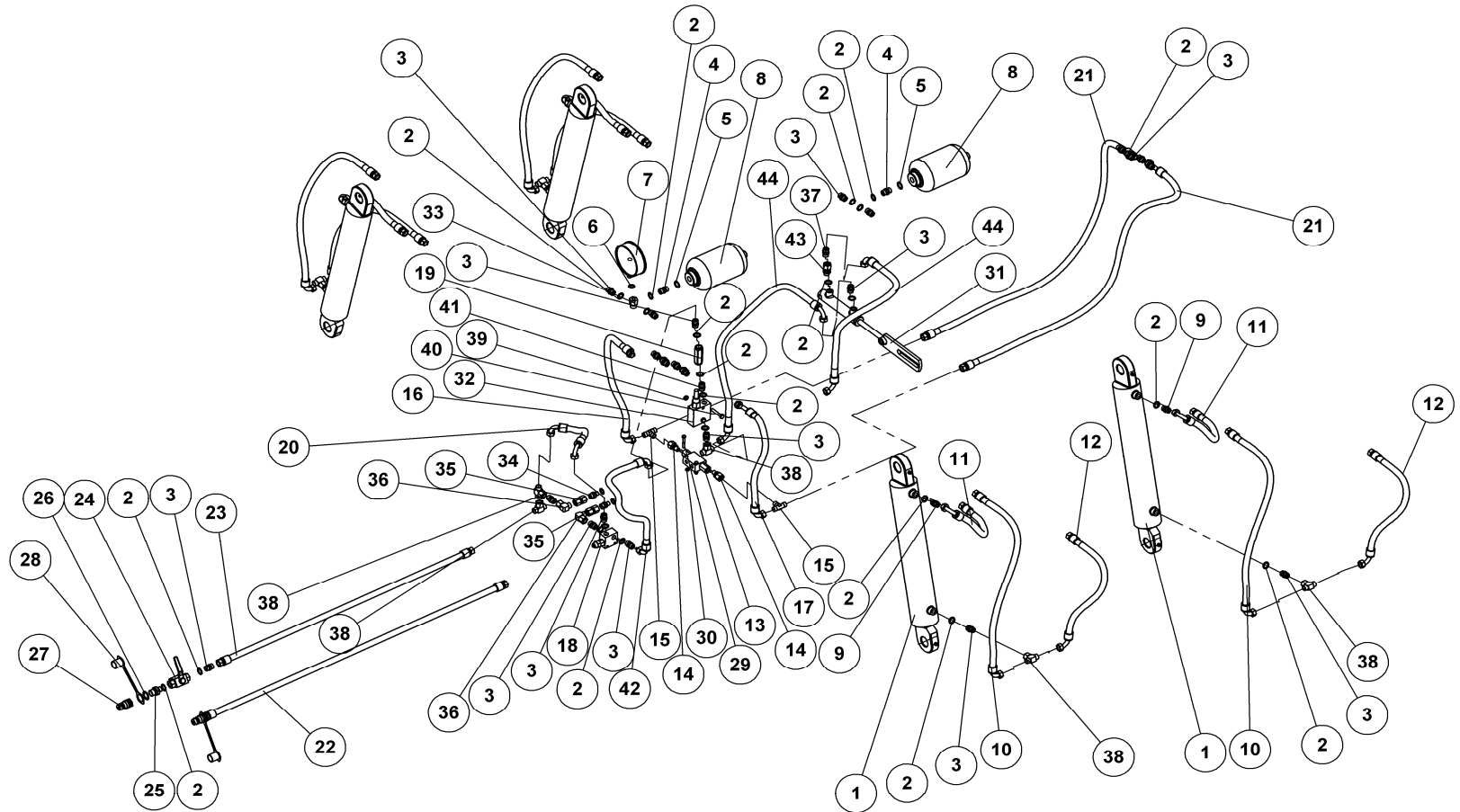

HYDRAULIK TIL OPKLAP TALL.

HYDRAULIK AUS/ZUSAMMENKLAPPEN
HYDRAULIC FOLDING
HYDRAULIQUE DE REPLIAGE

80539



HYDRAULIK TIL OPKLAP TALL.

HYDRAULIK AUS/ZUSAMMENKLAPPEN
HYDRAULIC FOLDING
HYDRAULIQUE DE REPLIAGE

80539

Pos.	Qty.	Part nr.	Benævnelse	Bezeichnung	Description	Designation
1	4	91825	CYLINDER 80/40X400	ZYLINDER	CYLINDER	CYLINDRE
2	38	91028	3/8" BONDED SEALS PAKRING	BONDED SEALS PAKRING	BONDED SEAL WASHER	JOINT BONDED SEALS
3	27	91003	BRYSTNIPPEL M18 / 3/8" RG GALV.	VERSCHRAUBUNG	HEXAGON NIPPLE CONNECTOR	RACCORD DE JONCTIONS MÂLES
4	2	91077	Lige forskrning M18 x 3/8"	GERADE VERSCHRAUBUNG	STRAIGHT CONNECTION	JOINT DROIT
5	2	91026	M18 BONDED SEALS PAKRING	M18 BONDED SEALS PAKRING	BONDED SEAL WASHED	JOINT BONDED SEALS
6	3	91027	1/4" BONDED SEALS PAKRING	BONDED SEALS PAKRING	BONDED SEAL WASHER	JOINT BONDED SEALS
7	1	91256	MANOMETER 1/4" RG	MANOMETER	MANOMETER	MANOMÈTRE
8	2	91248	AKKUMULATOR 1 L H1000R - 40 BAR	AKKUMULATOR	ACCUMULATOR	ACCUMULATEUR
9	4	91134	DRØVL-BRYSTNIPPEL M18 X 3/8" - ¥1,0	DROSSEL-VERSCHRAUBUNG	THROTTLE, HEXAGON NIPPLE CONNECTOR	RACCORD DE JONCTIONS MÂLES-GRIVE
10	4	80551	SLANGE M18 V + M18 L L=750 MM	SCHLAUCH	HOSE	TUYAU
11	4	80552	SLANGE M18 V + M18 L L= 290 MM	SCHLAUCH	HOSE	TUYAU
12	4	80572	SLANGE M18 V + M18 L L=480 MM	SCHLAUCH	HOSE	TUYAU
13	1	27396	PILOTSTYRET KONTRAVENTIL 1/4" - ENKELT	PILOTGESTEUERTES SPERRVENTIL EINFACH	PILOT-OPERATED CHECK VALVE, SINGLE	CLAPET DE BLOCAGE PILOTE SIMPLE
14	2	91114	LIGE FORSKRUNING 1/4"MALE / M18 FEMALE	GERADE VERSCHRAUBUNG	STRAIGHT CONNECTION	JOINT DROIT
15	2	91006	T-STYKKE M18X1.5 P-TV 12L	T-STÜCK	T-PIECE	T-PIECE
16	1	80573	SLANGE M18 V + M18 V L=520 MM	SCHLAUCH	HOSE	TUYAU
17	1	80554	SLANGE M18 V + M18 V L=420 MM	SCHLAUCH	HOSE	TUYAU
18	1	71230	OVERTRYKSVENTIL 70 BAR	ÜBERDRUCKVENTIL	PRESSURE RELIEF VALVE	VALVE DE SUR-PRESSION
19	1	91315	DRØVLE KONTRA 3/8" - 2,5 MM BLÆND	CLAPET DE BLOCAGE PILOTE	THROTTLE AND CHECK VALVE, CAP	DROSSEL KONTRA
20	1	80558	SLANGE M18 V + M18 V L=300 MM	SCHLAUCH	HOSE	TUYAU
21	2	80574	SLANGE M18 V + M18 L L=1300 MM	SCHLAUCH	HOSE	TUYAU
22	1	80559	SLANGE HAN + M18 L L=4100 MM	SCHLAUCH	HOSE	TUYAU
23	1	80560	SLANGE M18 L + M18 L=4000 MM	SCHLAUCH	HOSE	TUYAU
24	1	50573	VENTIL KH-R 3/8 NW10 ORSTA	KUGELHAHN	VALVE	VANETTE 3/8"
25	1	91074	BRYSTNIPPEL 1/2"RG /3/8"RG GALV	VERSCHRAUBUNG	HEXAGON NIPPLE CONNECTOR	RACCORD DE JONCTIONS MÂLES
26	1	91029	1/2" BONDED SEALS PAKRING	BONDED SEALS PAKRING	BONDED SEAL WASHER	JOINT BONDED SEALS
27	1	91010	LYNKOBLING 1/2" HANPART GALV.	LEUCHTKUPPLUNG	QUICK COUPLING, MALE	VALVE MÂLE PUSH PULL
28	1	91012	BLÆNDHÆTTE FOR HANSTIK 1/2" RØD	STAUBKAPPE ROT	CAP FOR MALE PLUG 1/2", RED	CHAPEAU VALVE POUR PRISE MÂLE ROUGE
29	2	92252	BOLT 6x45 8.8 GALV.	SCHRAUBE	SCREW	BOULON
30	2	92027	MØTRIK M6 GALV. kl.8	MUTTER	NUT	ÉCROU
31	1	77827	CYL. MED AFLANGHUL	ZYLINDER	RAN	VERRIN
32	1	71232	SEKVENSVENTIL 3/8" - 40 l/min	SEQUENSVENTIL	SEQUENCE VALVE	VALVE DE SÉQUENCE
33	1	91089	BRYSTNIPPEL 3/8"MALE 1/4"FEMALE	VERSCHRAUBUNG	HEXAGON NIPPLE CONNECTOR	RACCORD DE JONCTIONS MÂLES
34	2	91045	LIGE FORSKRUNING M18 x 1/4"	GERADE VERSCHRAUBUNG	STRAIGHT CONNECTION	JOINT DROIT
35	2	91025	RØRSTUDS M2 OML.Ø 12-L. M/O	GERADE VERSCHRAUBUNG	STRAIGHT CONNECTION	JOINT DROIT
36	2	91041	STILBAR VINK.FORSKR.Ø 12-L-D	WINKELBEFESTIGUNG	CONNECTOR	JOINT D'ANGLE
37	2	91004	Lige forskrning M18 x M18	GERADE VERSCHRAUBUNG	STRAIGHT CONNECTION	JOINT DROIT
38	7	91024	STILB. T-FORSKR.Ø 12-L M/OR-D	WINKELBEFESTIGUNG	CONNECTOR	JOINT D'ANGLE
39	2	92028	MØTRIK M8 GALV. kl.8	MUTTER	NUT	ÉCROU
40	2	92266	BOLT 8x50 8.8 GALV.	SCHRAUBE	SCREW	BOULON
41	1	91002	BRYSTNIPPEL 3/8"RG / 3/8"RG GALV	VERSCHRAUBUNG	HEXAGON NIPPLE CONNECTOR	RACCORD DE JONCTIONS MÂLES
42	1	80660	SLANGE M18 V + M18 V L=400 MM	SCHLAUCH	HOSE	TUYAU
43	1	91113	LIGE FORSKR. P-EGES 12 LR-WD-SV	GERADE VERSCHRAUBUNG	STRAIGHT CONNECTION	JOINT DROIT
44	2	80661	SLANGE M18 V + M18 V L=600 MM	SCHLAUCH	HOSE	TUYAU

Hydraulik til vinkeljust. 600, hyd. Winkelregulierung, hyd. angle adjustment, ajustage d'angle hyd.

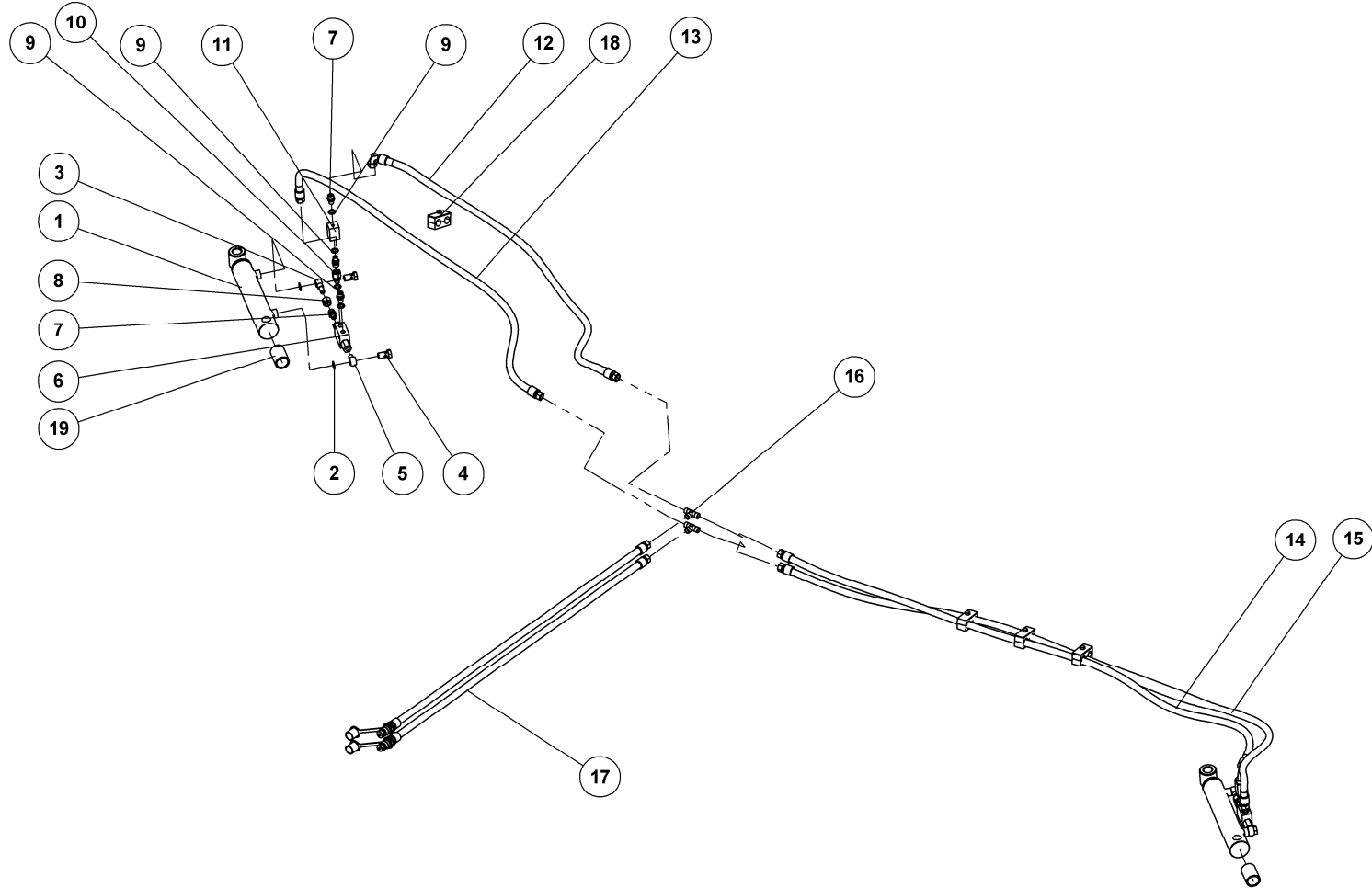

HYDRAULIK TIL VINKELJUST. 600

HYD. WINKELREGULIERUNG
HYD. ANGLE ADJUSTMENT
AJUSTAGE D'ANGLE HYD.

80540



HYDRAULIK TIL VINKELJUST. 600

80540

HYD. WINKELREGULIERUNG
HYD. ANGLE ADJUSTMENT
AJUSTAGE D'ANGLE HYD.

Pos.	Qty.	Part nr.	Benævneelse	Bezeichnung	Description	Designation
1	2	91840	CYLINDER 50/30/150 ø25 L=350	ZYLINDER	CYLINDER	VERRIN
2	4	91028	3/8" BONDED SEALS PAKRING	BONDED SEALS PAKRING	BONDED SEAL WASHER	JOINT BONDED SEALS
3	2	91058	3/8" BANJOFORSKRUNING M. M18 RØR	DREHVERSCHRAUBUNG M18	SWIRVEL BANJO M18 TUBE	RACCORD TOUN. M 18 AVEC TUBE
4	4	91060	BANJO BOLT 3/8" BSP	DREHVERSC. SCHRAUBE	SWIRVEL BOLT	RACCORD TOUN
5	2	91059	BANJOFORSKRUNING 1/4"	DREHVERSCHRAUBUNG 1/4"	SWIRVEL BANJO 1/4"	RACCORD TOURNANT
6	2	51311	PILOTSTYRET KONTRAVENTIL 1/4 - DOBBELT	PILOTGESTEUERTES SPERRVENTIL DOPPELT	PILOT-OPERATED CHECK VALVE, DOUBLE	CLAPET DE BLOCAGE PILOTE DOUBLE
7	8	91045	LIGE FORSKRUNING M18 x 1/4"	GERADE VERSCHRAUBUNG	STRAIGHT CONNECTION	JOINT DROIT
8	2	91103	OMLØBER M/SKÆRERING M18	VERSCHRAUBUNG	ADAPTOR	RACCORD
9	8	91027	1/4" BONDED SEALS PAKRING	BONDED SEALS PAKRING	BONDED SEAL WASHER	JOINT BONDED SEALS
10	2	91114	LIGE FORSKRUNING 1/4"MALE / M18 FEMALE	GERADE VERSCHRAUBUNG	STRAIGHT CONNECTION	JOINT DROIT
11	2	91230	JUSTERBAR DRØVLEVENTIL 1/4 "	REGULIERBARE DROSSEL	ADJUSTABLE THROTTLE	AILE RÉGLABLE GRIVE
12	1	80570	SLANGE M18 V + M18 L L=1350 MM	SCHLAUCH	HOSE	TUYAU
13	1	80562	SLANGE M18 L + M18 L L= 1550 MM	SCHLAUCH	HOSE	TUYAU
14	1	80563	SLANGE M18 V + M18 L L=2300 MM	SCHLAUCH	HOSE	TUYAU
15	1	80564	SLANGE M18 L + M18 L L= 2400 MM	SCHLAUCH	HOSE	TUYAU
16	2	91006	T-STYKKE M18X1.5 P-TV 12L	T-STÜCK	T-PIECE	T-PIECE
17	2	80565	SLANGE HAN + M18 L L=4250 MM	SCHLAUCH	HOSE	TUYAU
18	4	91309	PLASTKLAMME, BOLT, DÆKPLADE 3/8" KPL	PLASTIK KLAMMER	PLASTIC HOSE CLAMP	CROCHET EN PLASTIQUE
19	2	80792	AFSTANDSSTYKKE FOR CYLINDER 91840	ABSTANDSSTÜCK	SPACER	ENTRETOISE

HYDRAULIK TIL VINKELJUST. 500

80541

Hyd. Winkelregulierung
Hyd. angle adjustment
Ajustage d'angle hyd.

Pos.	Qty.	Part nr.	Benævneelse	Bezeichnung	Description	Designation
13	1	80566	Slange m18 v + m18 l l=1800 mm	Schlauch	Hose	Tuyau
14	1	80567	Slange m18 l + m18 l l=1900 mm	Schlauch	Hose	Tuyau
15	1	80568	Slange m18 v + m18 l l=1700 mm	Schlauch	Hose	Tuyau
16	1	80569	Slange m18 l + m18 l l=1800 mm	Schlauch	Hose	Tuyau

Hydraulik til stensikring maxidisc 400, hydraulik, hydraulic, hydraulique

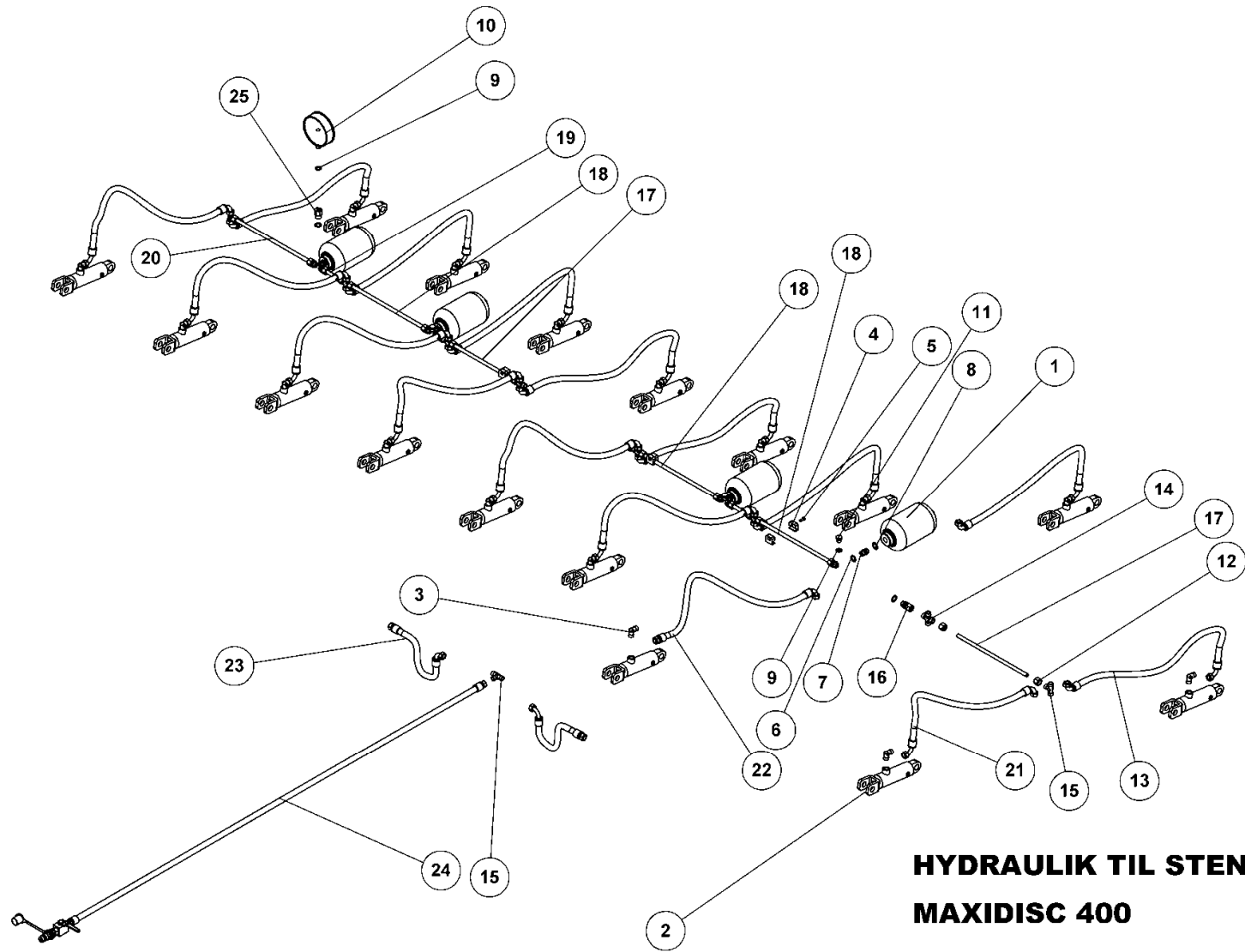

**HYDRAULIK TIL STENSIKRING
MAXIDISC 400**

HYDRAULIK
HYDRAULIC
HYDRAULIQUE

80276



HYDRAULIK TIL STENSIKRING

MAXIDISC 400

80276

HYDRAULIK
HYDRAULIC
HYDRAULIQUE

Pos.	Qty.	Part nr.	Benævnelse	Bezeichnung	Description	Designation
1	4	91262	AKKUMULATOR 1 L H1000R - 120 BAR	AKKUMULATOR	ACCUMULATOR	ACCUMULATEUR
2	16	80454	CYLINDER K-4020050 GA20 2FH20 M. GAFFEL	ZYLINDER	RAN	VERRIN
3	16	91005	Vinkel 3/8" x M18s	WINKEL	CONNECTOR	ANGLE
4	6	91303	PLASTKLAMME 12MM	PLASTIK KLAMMER	PLASTIC HOSE CLAMP	CROCHET EN PLASTIQUE
5	3	92248	SKRUE 6 x 16 8.8 DIN 7985A	SCHRAUBE	SCREW	BOULON
6	13	91028	3/8" BONDED SEALS PAKRING	BONDED SEALS PAKRING	BONDED SEAL WASHER	JOINT BONDED SEALS
7	10	91003	BRYSTNIPPEL M18 / 3/8" RG GALV.	VERSCHRAUBUNG	HEXAGON NIPPLE CONNECTOR	RACCORD DE JONCTIONS MÂLES
8	4	91026	M18 BONDED SEALS PAKRING	M18 BONDED SEALS PAKRING	BONDED SEAL WASHED	JOINT BONDED SEALS
9	4	91027	1/4" BONDED SEALS PAKRING	BONDED SEALS PAKRING	BONDED SEAL WASHER	JOINT BONDED SEALS
10	1	91256	MANOMETER 1/4" RG	MANOMETER	MANOMETER	MANOMÈTRE
11	3	91092	SLUTPROP M/PAKNING 1/4"	STÖPSEL	PLUG	BOUCHON
12	17	91103	OMLØBER M/SK/ÆRERING M18	VERSCHRAUBUNG	ADAPTOR	RACCORD
13	8	80815	SLANGE M18 V + M18 V L=760 MM	SCHLAUCH	HOSE	TUYAU
14	6	91007	KRYD S M18 Ø12 GALV P-KV 12L	KREUZ	CROSS	CROIX
15	3	91006	T-STYKKE M18X1.5 P-TV 12L	T-STÜCK	T-PIECE	T-PIÈCE
16	2	91113	LIGE FORSKR. P-EGES 12 LR-WD-SV	GERADE VERSCHRAUBUNG	STRAIGHT CONNECTION	JOINT DROIT
17	2	9314000340XXXXXX	HYDRAULIKRØR 12X1.5	ROHR	TUBE	TUBE
18	3	9314000370XXXXXX	HYDRAULIKRØR 12X1.5	ROHR	TUBE	TUBE
19	2	9314000100XXXXXX	HYDRAULIKRØR 12X1.5	ROHR	TUBE	TUBE
20	1	9314000395XXXXXX	HYDRAULIKRØR 12X1.5	ROHR	TUBE	TUBE
21	7	80816	SLANGE M18 V + M18 V L=550 MM	SCHLAUCH	HOSE	TUYAU
22	1	80817	SLANGE M18 V + M18 L L=580 MM	SCHLAUCH	HOSE	TUYAU
23	2	80818	SLANGE M18 V + M18 L L=750 MM	SCHLAUCH	HOSE	TUYAU
24	1	80819	SLANGE HAN + HANE + M18 L	SCHLAUCH	HOSE	TUYAU
25	1	91089	BRYSTNIPPEL 3/8"MALE 1/4"FEMALE	VERSCHRAUBUNG	HEXAGON NIPPLE CONNECTOR	RACCORD DE JONCTIONS MÂLES

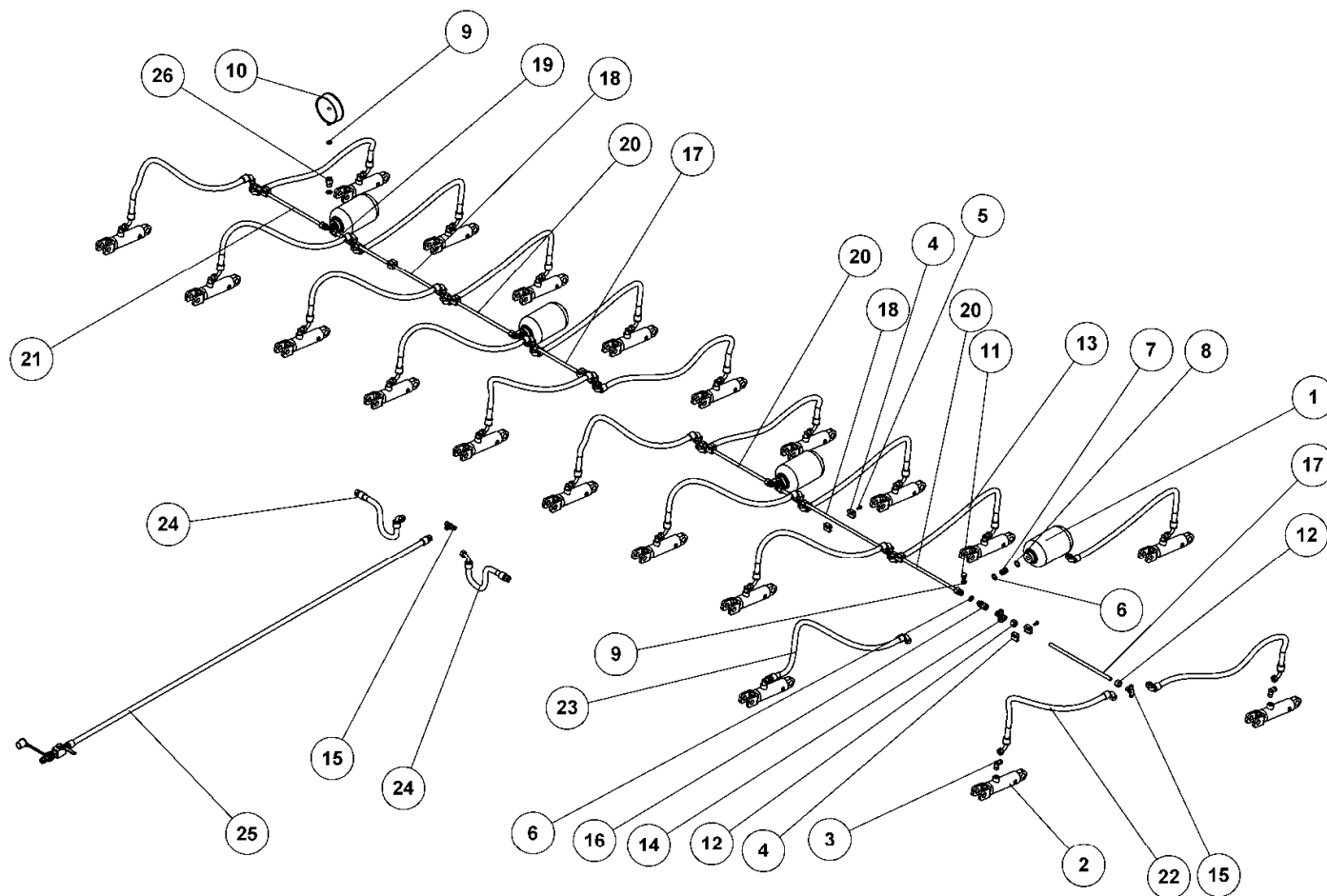

**HYDRAULIK TIL STENSIKRING
MAXIDISC 500**

HYDRAULIK
HYDRAULIC
HYDRAULIQUE

80277



HYDRAULIK TIL STENSIKRING

MAXIDISC 500

80277

HYDRAULIK
HYDRAULIC
HYDRAULIQUE

Pos.	Qty.	Part nr.	Benævnelse	Bezeichnung	Description	Designation
1	4	91262	AKKUMULATOR 1 L H1000R - 120 BAR	AKKUMULATOR	ACCUMULATOR	ACCUMULATEUR
2	20	80454	CYLINDER K-4020050 GA20 2FH20 M. GAFFEL	ZYLINDER	RAN	VERRIN
3	20	91005	Vinkel 3/8" x M18s	WINKEL	CONNECTOR	ANGLE
4	16	91303	PLASTKLAMME 12MM	PLASTIK KLAMMER	PLASTIC HOSE CLAMP	CROCHET EN PLASTIQUE
5	8	92248	SKRUE 6 x 16 8.8 DIN 7985A	SCHRAUBE	SCREW	BOULON
6	14	91028	3/8" BONDED SEALS PAKRING	BONDED SEALS PAKRING	BONDED SEAL WASHER	JOINT BONDED SEALS
7	11	91003	BRYSTNIPPEL M18 / 3/8" RG GALV.	VERSCHRAUBUNG	HEXAGON NIPPLE CONNECTOR	RACCORD DE JONCTIONS MÂLES
8	4	91026	M18 BONDED SEALS PAKRING	M18 BONDED SEALS PAKRING	BONDED SEAL WASHED	JOINT BONDED SEALS
9	4	91027	1/4" BONDED SEALS PAKRING	BONDED SEALS PAKRING	BONDED SEAL WASHER	JOINT BONDED SEALS
10	1	91256	MANOMETER 1/4" RG	MANOMETER	MANOMETER	MANOMÈTRE
11	3	91092	SLUTPROP M/PAKNING 1/4"	STÖPSEL	PLUG	BOUCHON
12	20	91103	OMLØBER M/SKÆRERING M18	VERSCHRAUBUNG	ADAPTOR	RACCORD
13	10	80815	SLANGE M18 V + M18 V L=760 MM	SCHLAUCH	HOSE	TUYAU
14	8	91007	KRYDS M18 Ø12 GALV. P-KV 12L	KREUZ	CROSS	CROIX
15	3	91006	T-STYKKE M18X1.5 P-TV 12L	T-STÜCK	T-PIECE	T-PIÈCE
16	2	91113	LIGE FORSKR. P-EGES 12 LR-WD-SV	GERADE VERSCHRAUBUNG	STRAIGHT CONNECTION	JOINT DROIT
17	2	9314000340XXXXXX	HYDRAULIKRØR 12X1.5	ROHR	TUBE	TUBE
18	2	9314000475XXXXXX	HYDRAULIKRØR 12X1.5	ROHR	TUBE	TUBE
19	2	9314000100XXXXXX	HYDRAULIKRØR 12X1.5	ROHR	TUBE	TUBE
20	3	9314000370XXXXXX	HYDRAULIKRØR 12X1.5	ROHR	TUBE	TUBE
21	1	9314000385XXXXXX	HYDRAULIKRØR 12X1.5	ROHR	TUBE	TUBE
22	9	80816	SLANGE M18 V + M18 V L=550 MM	SCHLAUCH	HOSE	TUYAU
23	1	80817	SLANGE M18 V + M18 L L=580 MM	SCHLAUCH	HOSE	TUYAU
24	2	80818	SLANGE M18 V + M18 L L=750 MM	SCHLAUCH	HOSE	TUYAU
25	1	80819	SLANGE HAN + HANE + M18 L	SCHLAUCH	HOSE	TUYAU
26	1	91089	BRYSTNIPPEL 3/8"MALE 1/4"FEMALE	VERSCHRAUBUNG	HEXAGON NIPPLE CONNECTOR	RACCORD DE JONCTIONS MÂLES

Hydraulik til stensikring maxidisc 600, hydraulik, hydraulic, hydraulique

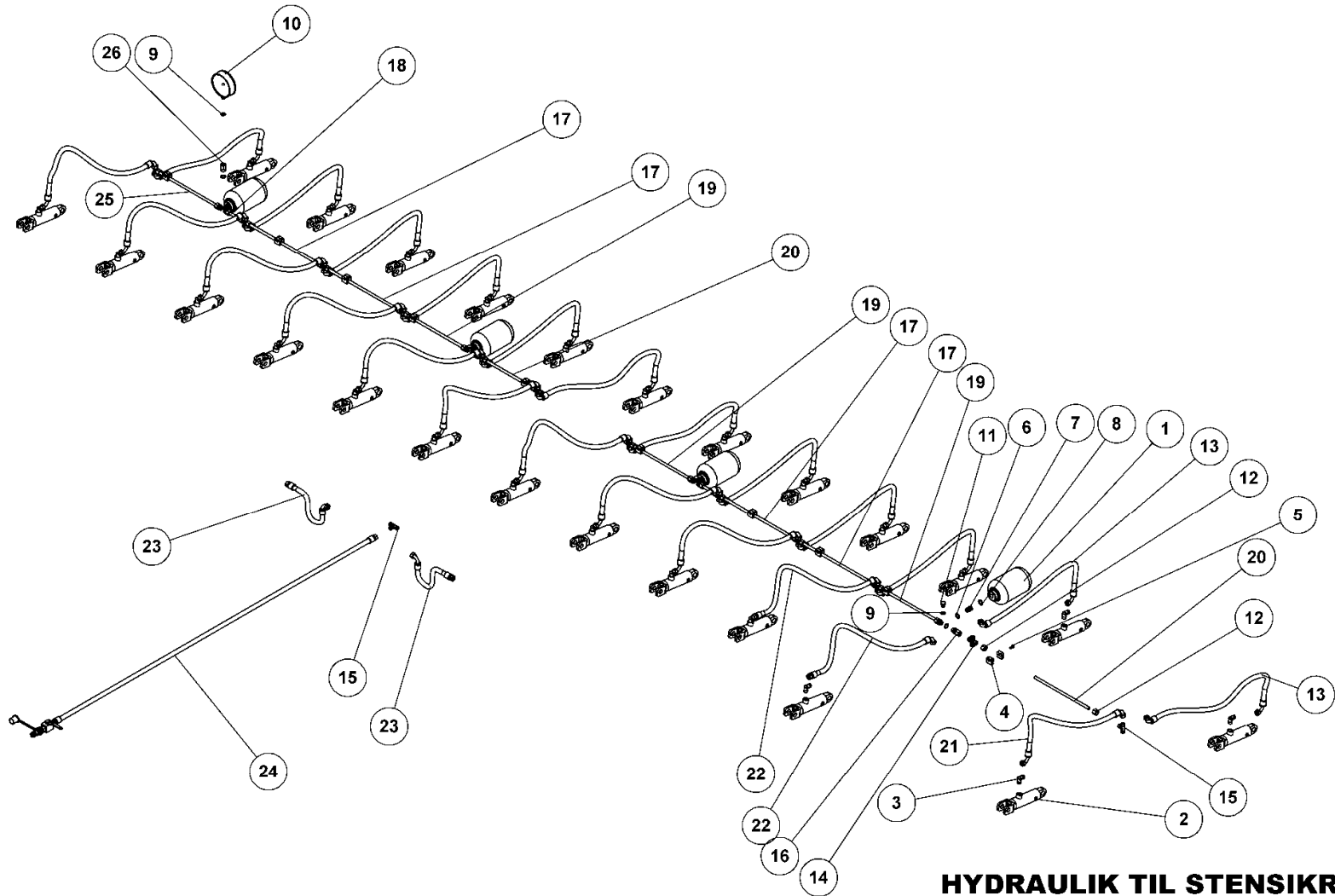

HYDRAULIK TIL STENSIKRING MAXIDISC 600

HYDRAULIK
HYDRAULIC
HYDRAULIQUE

80278



HYDRAULIK TIL STENSIKRING

MAXIDISC 600

80278

HYDRAULIK
HYDRAULIC
HYDRAULIQUE

Pos.	Qty.	Part nr.	Benævnelse	Bezeichnung	Description	Designation
1	4	91262	AKKUMULATOR 1 L H1000R - 120 BAR	AKKUMULATOR	ACCUMULATOR	ACCUMULATEUR
2	24	80454	CYLINDER K-4020050 GA20 2FH20 M. GAFFEL	ZYLINDER	RAN	VERRIN
3	24	91005	Vinkel 3/8" x M18s	WINKEL	CONNECTOR	ANGLE
4	20	91303	PLASTKLAMME 12MM	PLASTIK KLAMMER	PLASTIC HOSE CLAMP	CROCHET EN PLASTIQUE
5	10	92248	SKRUE 6 x 16 8.8 DIN 7985A	SCHRAUBE	SCREW	BOULON
6	13	91028	3/8" BONDED SEALS PAKRING	BONDED SEALS PAKRING	BONDED SEAL WASHER	JOINT BONDED SEALS
7	10	91003	BRYSTNIPPEL M18 / 3/8" RG GALV.	VERSCHRAUBUNG	HEXAGON NIPPLE CONNECTOR	RACCORD DE JONCTIONS MÂLES
8	4	91026	M18 BONDED SEALS PAKRING	M18 BONDED SEALS PAKRING	BONDED SEAL WASHED	JOINT BONDED SEALS
9	4	91027	1/4" BONDED SEALS PAKRING	BONDED SEALS PAKRING	BONDED SEAL WASHER	JOINT BONDED SEALS
10	1	91256	MANOMETER 1/4" RG	MANOMETER	MANOMETER	MANOMÈTRE
11	3	91092	SLUTPROP M/PAKNING 1/4"	STÖPSEL	PLUG	BOUCHON
12	24	91103	OMLØBER M/SKÆRERING M18	VERSCHRAUBUNG	ADAPTOR	RACCORD
13	12	80815	SLANGE M18 V + M18 V L=760 MM	SCHLAUCH	HOSE	TUYAU
14	10	91007	KRYDS M18 Ø12 GALV. P-KV 12L	KREUZ	CROSS	CROIX
15	3	91006	T-STYKKE M18X1.5 P-TV 12L	T-STÜCK	T-PIECE	T-PIÈCE
16	2	91113	LIGE FORSKR. P-EGES 12 LR-WD-SV	GERADE VERSCHRAUBUNG	STRAIGHT CONNECTION	JOINT DROIT
17	4	9314000475XXXXXX	HYDRAULIKRØR 12X1.5	ROHR	TUBE	TUBE
18	2	9314000100XXXXXX	HYDRAULIKRØR 12X1.5	ROHR	TUBE	TUBE
19	3	9314000370XXXXXX	HYDRAULIKRØR 12X1.5	ROHR	TUBE	TUBE
20	2	9314000340XXXXXX	HYDRAULIKRØR 12X1.5	ROHR	TUBE	TUBE
21	10	80816	SLANGE M18 V + M18 V L=550 MM	SCHLAUCH	HOSE	TUYAU
22	2	80817	SLANGE M18 V + M18 L L=590 MM	SCHLAUCH	HOSE	TUYAU
23	2	80818	SLANGE M18 V + M18 L L=750 MM	SCHLAUCH	HOSE	TUYAU
24	1	80819	SLANGE HAN + HANE + M18 L	SCHLAUCH	HOSE	TUYAU
25	1	9314000385XXXXXX	HYDRAULIKRØR 12X1.5	ROHR	TUBE	TUBE
26	1	91089	BRYSTNIPPEL 3/8" MALE 1/4" FEMALE	VERSCHRAUBUNG	HEXAGON NIPPLE CONNECTOR	RACCORD DE JONCTIONS MÂLES

Lygtesæt, Light set, Leuchtssatz
Lygtesæt maxidisc 500+600 kpl., leuchtssatz, light set, ensemble de phares

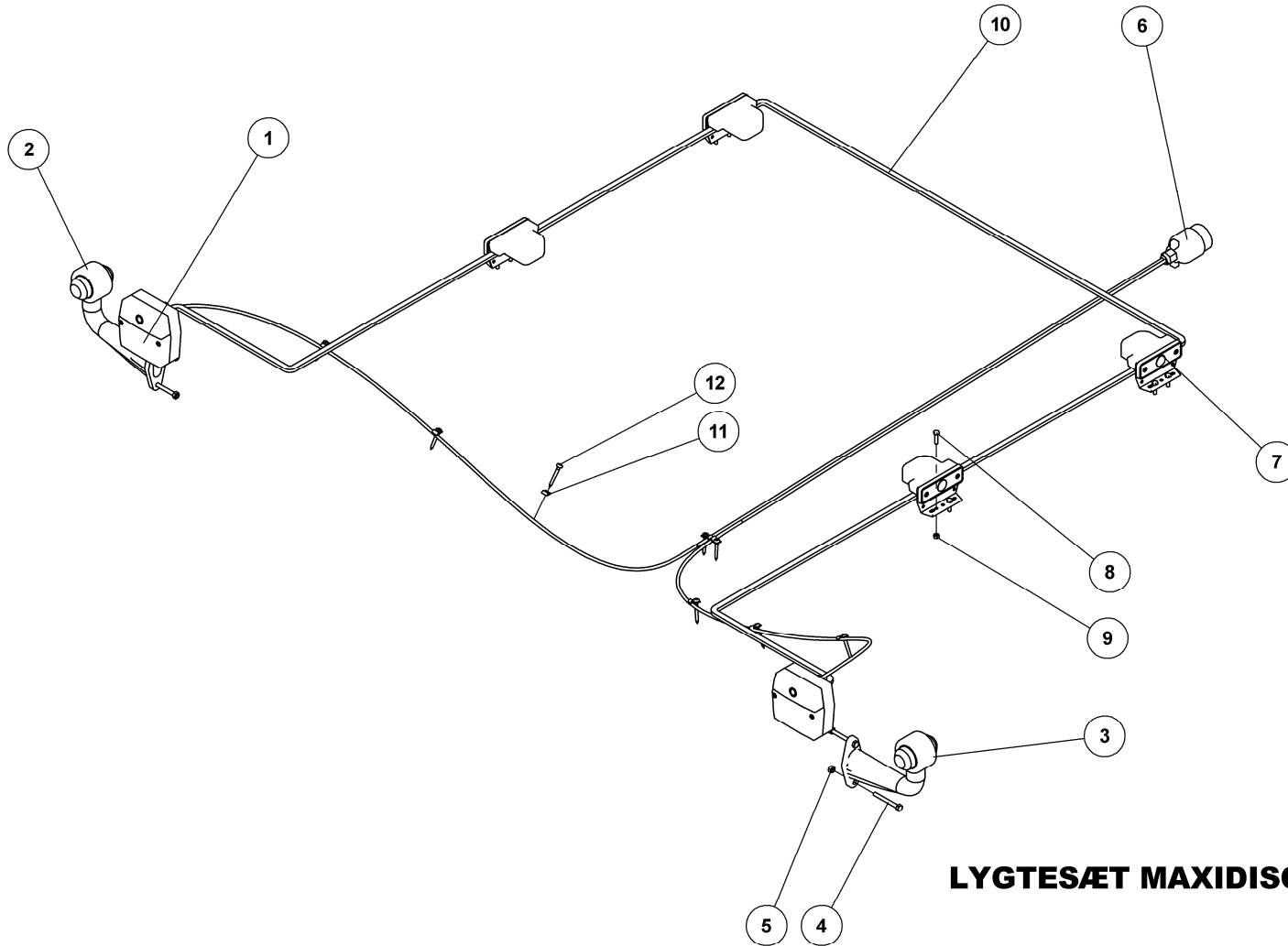

LYGTESÆT MAXIDISC 500+600 KPL.

LEUCHTSSATZ
LIGHT SET
ENSEMBLE DE PHARES

80190

side 52



LYGTESÆT MAXIDISC 500+600 KPL.

80190

LEUCHTSSATZ
LIGHT SET
ENSEMBLE DE PHARES

Pos.	Qty.	Part nr.	Benævnelse	Bezeichnung	Description	Designation
1	2	89400	BAGLYGTE MINIPPOINT U/NR.PL.LYS	RÜCKLICHT	MINIPPOINT BACKLIGHTS W/OUT LICENSE PLATE LIGHT	PHARE ARRIÈRE
2	1	89410	MARKERINGSLYS VENSTRE 0,3M P&R	LEUCHTE LINKS	MARKING LIGHTS, LEFT	LUMIÈRE DE SIGNALISATION GAUCHE
3	1	89411	MARKERINGSLYS HØJRE 0,3M P&R	LEUCHTE RECHTS	MARKING LIGHTS, RIGHT	LUMIÈRE DE SIGNALISATION DROITE
4	4	92253	BOLT 6x55 8.8 GALV.	SCHRAUBE	SCREW	BOULON
5	4	92027	MØTRIK M6 GALV. kl.8	MUTTER	NUT	ÉCROU
6	1	89430	KABELSÆT 2x7M - 7-POL STIK	KABELSATZ	CABLE ASSEMBLY	ENSEMBLE DE CÂBLES
7	4	89420	SIDEMARKERINGSLYS M/VINKEL 0,25M P&R	SEITENMARKIERUNGSLEUCHTE MIT WINKEL	SIDE MARKING LIGHTS WITH ANGLE	LUMIÈRE DE SIGNALISATION LATÉRALE AVEC ANGLE
8	8	92238	BOLT 5x20 8.8 GALV.	SCHRAUBE	SCREW	BOULON
9	8	92026	MØTRIK M 5 GALV. kl.8	MUTTER	NUT	ÉCROU
10	1	89540	FLADKABEL 2X7M P&R PVC	FLACHKABEL	FLAT CABLE	CÂBLE MÉPLAT
11	8	88146	KABELBØJLER 5 mm	KABELHALTER	CABLE BRACKET	COLLIER DE CÂBLE
12	8	92386	PLADESKRUE PH Ø 4.8X40	SCHRAUBE	PLATE SCREW	VIS DE PLAQUE

Bremser, Brakes, Bremse

Trykluftbremser på hjulstel, bremse an rad gestell, breaks on wheel frame, frein du cadre de roue

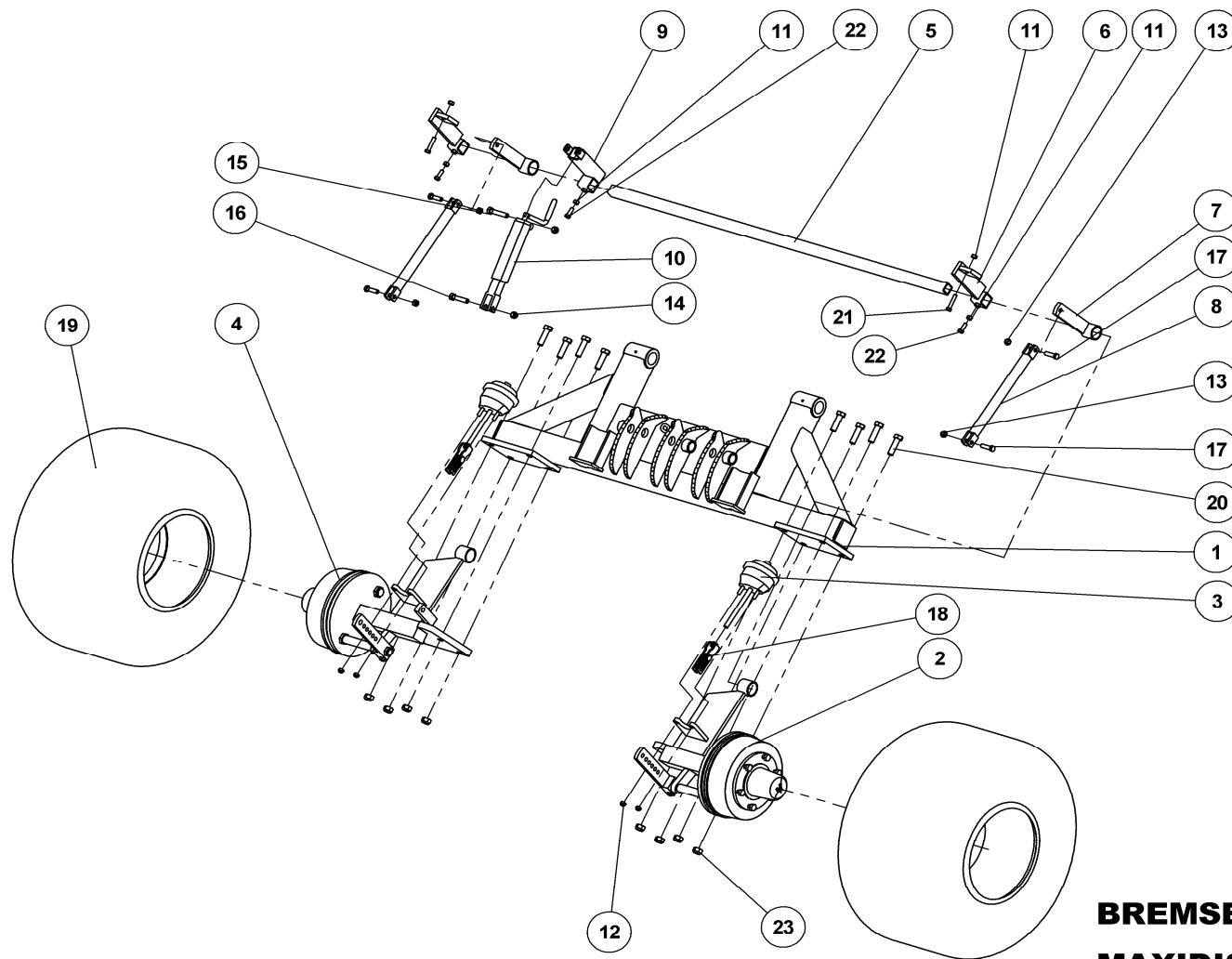

BREMSE PÅ HJULSTEL MAXIDISC 600

BREMSE AN RAD GESTELL
BREAKS ON WHEEL FRAME
FREIN DU CADRE DE ROUE

80302

side 54



BREMSER PÅ HJULSTEL

MAXIDISC 600

80302

BREMSE AN RAD GESTELL
BREAKS ON WHEEL FRAME
FREIN DU CADRE DE ROUE

Pos.	Qty.	Part nr.	Benævnelse	Bezeichnung	Description	Designation
1	1	80489	HJULSTEL, EN/TO CYLINDRE	RAD GESTELL	WHEEL FRAME	CADRE DE ROUE
2	1	80301	LUFTBREMSNAV VENSTRE MAXIDISC (5506)	BREMSNABE LINKS	BRAKE HUB LEFT	MOYEU DE FREIN/GOUPILLE GAUCHE
3	2	88203	MEMBRANCYLINDER 12"	MEMBRANZYLINDER	MEMBRANE CYLINDER	CYLINDRE À MEMBRANE
4	1	80300	LUFTBREMSNAV HØJRE MAXIDISC (5506)	BREMSNABE RECHTS	BRAKE HUB RIGHT	MOYEU DE FREIN/GOUPILLE GAUCHE DROITE
5	1	74891	FIRK-RØR 40X40X4 - 1680 MM	VIERTKANT ROHR	SQUARE TUBE	TUBE CARRÉ
6	2	37785	JUSTERBAR BREMSNØGLE KOMPLET	BREMSARM	BRAKE ARM FOR BRAKE LEVER	BRAS DE FREIN POUR BÂTON DE FREIN
7	2	37784	BREMSNØGLE MED RUND RØR	BREMSARM	BRAKE ARM FOR BRAKE LEVER	BRAS DE FREIN POUR BÂTON DE FREIN
8	2	37782	FORBINDELSESTANG HÅNDBREMSE	VERBINDUNGSSTANGE	CONNECTING LINK	BRAS DE CONNEXION
9	1	37783	BREMSNØGLE FOR SPINDEL	BREMSSTANGE	BRAKE LEVER	BÂTON DE FREIN
10	1	21465	SPINDEL SHF 6-01	SPINDEL	SPINDLE	FUSEAU
11	5	92030	MØTRIK M12 GALV. kl.8	MUTTER	NUT	ÉCROU
12	4	92050	MØTRIK M12 SELVLÅS. GLV. 8	MUTTER SELBSTSCHLIESSEND	SELFLOCKING NUT	ÉCROU DE SÉCURITÉ
13	4	92034	MØTRIK M14 SELVLÅS. GLV. 8	MUTTER	SELF-LOCKING NUT	ÉCROU
14	2	92051	MØTRIK M16 SELVLÅS. GLV. 8	MUTTER	SELF-LOCKING NUT	ÉCROU
15	1	92320	BOLT 16x80 8.8 GALV.	SCHRAUBE	SCREW	BOULON
16	1	92319	BOLT 16x70 8.8 GALV.	SCHRAUBE	SCREW	BOULON
17	4	92362	BOLT 14X50 8.8 GLV.	SCHRAUBE	SCREW	BOULON
18	2	88206	MONTERINGSSÆT LANG GAFFEL	MONTAGESATZ LANGE GABEL	MOUNTING SET, LONG FORK	ENSEMBLE DE MONTAGE FOURCHE LONGUE
19	2	74340	HJUL 500/50 X 17 - 14ply	RAD	WHEEL	ROUE
20	8	92342	BOLT 20x70 8.8 GALV.	SCHRAUBE	SCREW	BOULON
21	2	92298	BOLT 12x60 8.8 GALV.	SCHRAUBE	SCREW	BOULON
22	3	92542	BOLT 12x35 GLV. 8.8 (SÆTBOLT)	SCHRAUBE	SET SCREW	BOULON
23	8	92052	MØTRIK M 20 SELVLÅS. GALV. 8	MUTTER SELBSTGESICHERT	SELF-LOCKING NUT	ÉCROU DE SÉCURITÉ

Bremser på hjulstel

Maxidisc 500

80303

Bremse an rad gestell
Breaks on wheel frame
Frein du cadre de roue

Pos.	Qty.	Part nr.	Benævnelse	Bezeichnung	Description	Designation
3	2	88202	Membrancylinder 9"	Membranzyylinder	Membrane cylinder	Cylindre à membrane

EKSTRAUDSTYR, OPTIONS, ZUSATZAUSRÜSTUNG, ACCESSOIRES EN OPTION
Stænklap, Rupper plate, Spritzlappen

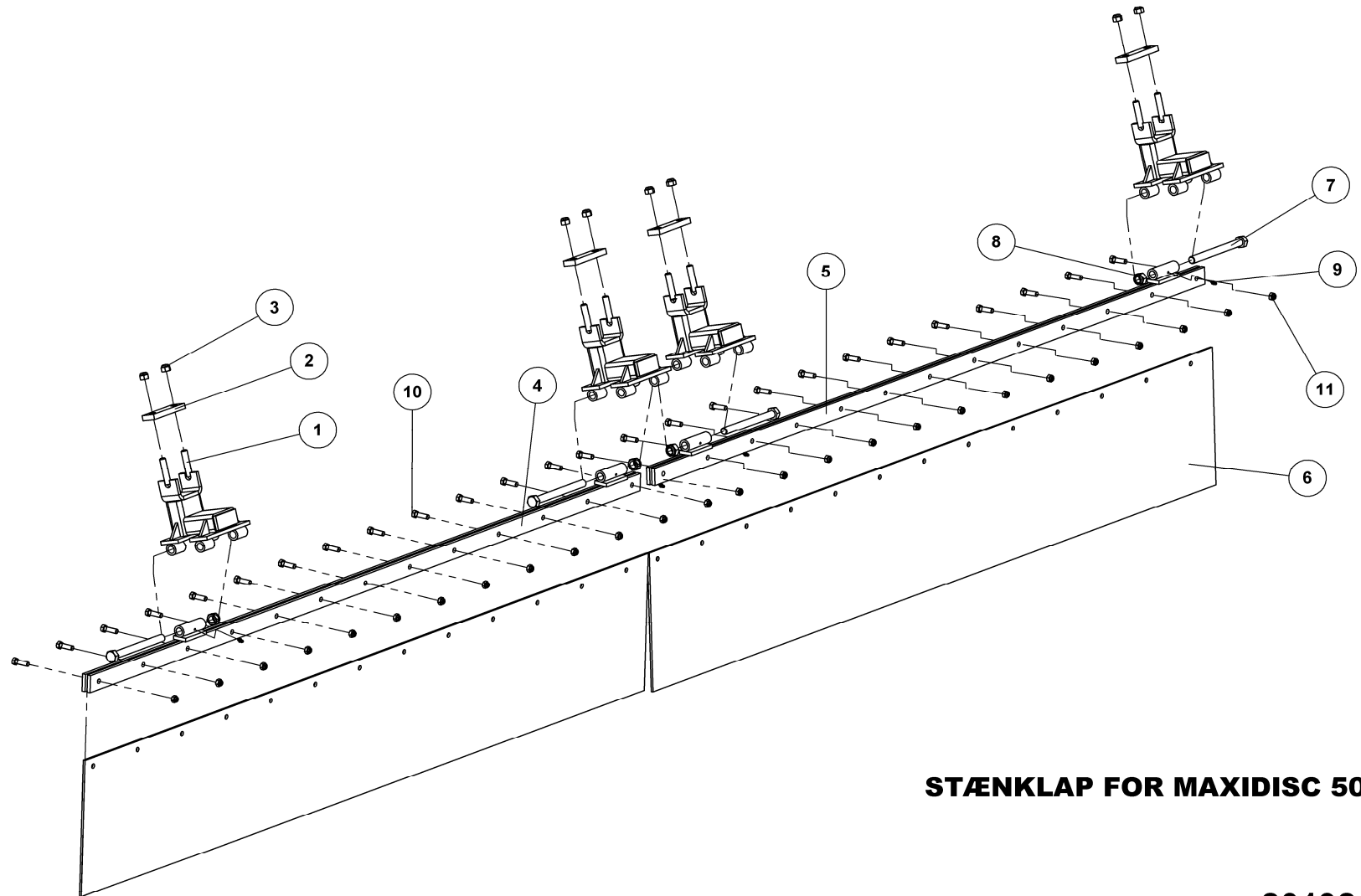

STÆNKLAP FOR MAXIDISC 500

80198



STÆNKLAP FOR MAXIDISC 500

80198

Pos.	Qty.	Part nr.	Benævnelse	Bezeichnung	Description	Designation
1	4	80372	HOLDER FOR STÆNKLAPPER	HALTER	BRACKET	SUPPORT
2	4	26354	SPÆNDEPLADE Ø17,5X98	PLATTE	PLATE	PLAQUE
3	8	92051	MØTRIK M16 SELVLÅS. GLV.8	MUTTER	SELF-LOCKING NUT	ÉCROU
4	1	80376	HOLDER FOR STÆNKLAP 500 HØJRE	HALTER	BRACKET	SUPPORT
5	1	80375	HOLDER FOR STÆNKLAP 500 VENSTRE	HALTER	BRACKET	SUPPORT
6	2	80926	STÆNKLAP 500	GUMMIPLATTE	RUBBER PLATE	PLAQUE EN CAOUTCHOUC
7	4	92348	BOLT 20x220 8.8 GALV.	SCHRAUBE	SCREW	BOULON
8	4	92052	MØTRIK M 20 SELVLÅS. GALV. 8	MUTTER SELBSTGESICHERT	SELF-LOCKING NUT	ÉCROU DE SÉCURITÉ
9	4	75889	SMØRENIPPEL M6X1 K	SCHMIERNIPPEL	GREASE NIPPLE	GRAISSEUR
10	26	92296	BOLT 12x40 8.8 GALV.	SCHRAUBE	SCREW	BOULON
11	26	92050	MØTRIK M12 SELVLÅS. GLV. 8	MUTTER SELBSTSCHLIESSEND	SELFLOCKING NUT	ÉCROU DE SÉCURITÉ

STÆNKLAP FOR MAXIDISC 600

80199

SCHUTZLEDER
MUDGUARD
BAVETTE

Pos.	Qty.	Part nr.	Benævnelse	Bezeichnung	Description	Designation
4	1	80374	HOLDER FOR STÆNKLAP 600 H	HALTER	BRACKET	SUPPORT
5	1	80373	HOLDER FOR STÆNKLAP 600 V	GUMMIPLATTE	RUBBER PLATE	PLAQUE EN CAOUTCHOUC